Chapter 8

Standards and Specifications

Issued February 2015

The U.S. Department of Agriculture (USDA) prohibits discrimination against its customers. If you believe you experienced discrimination when obtaining services from USDA, participating in a USDA program, or participating in a program that receives financial assistance from USDA, you may file a complaint with USDA. Information about how to file a discrimination complaint is available from the Office of the Assistant Secretary for Civil Rights. USDA prohibits discrimination in all its programs and activities on the basis of race, color, national origin, age, disability, and where applicable, sex (including gender identity and expression), marital status, familial status, parental status, religion, sexual orientation, political beliefs, genetic information, reprisal, or because all or part of an individual's income is derived from any public assistance program. (Not all prohibited bases apply to all programs.)

To file a complaint of discrimination, complete, sign, and mail a program discrimination complaint form, available at any USDA office location or online at www.ascr.usda.gov, or write to:

USDA
Office of the Assistant Secretary for Civil Rights
1400 Independence Avenue, SW.
Washington, DC 20250-9410

Or call toll free at (866) 632-9992 (voice) to obtain additional information, the appropriate office or to request documents. Individuals who are deaf, hard of hearing, or have speech disabilities may contact USDA through the Federal Relay service at (800) 877-8339 or (800) 845-6136 (in Spanish). USDA is an equal opportunity provider, employer, and lender.

Persons with disabilities who require alternative means for communication of program information (e.g., Braille, large print, audiotape, etc.) should contact USDA's TARGET Center at (202) 720-2600 (voice and TDD).

Acknowledgments

This chapter was developed through the efforts of the NRCS Snow Survey and Water Supply Forecasting Program employees. **Mike Strobel**, director; **Laurel Grimsted**, Information Systems Team leader; **Tom Perkins**, Water and Climate Services Team leader (retired); **Garry Schaefer**, Water and Climate Monitoring Team leader (retired); **Jim Marron**, resource conservationist (retired); **Tony Tolsdorf**, hydrologist; **Maggie Dunklee**, database manager; **Steve Dunn**, electronics technician; **David Garen**, hydrologist; **Dana Kuiper**, database manager (retired); **Rose Loehr**, operations specialist (retired); **Rashawn Tama**, hydrologist; and **John Weeks**, lead electronics technician, National Water and Climate Center, Portland, OR; and **Denice Schilling**, statistical assistant, National Water and Climate Center, Great Falls, MT, compiled the chapter along with comments and revisions.

Ron Abramovich, water supply specialist, Boise ID; **Austin Beard**, electronics technician, Bozeman, MT; **Marianne Hallet**, civil engineer (retired), **Randy Julander**, DCO supervisor, Utah; **Roy Kaiser**, water supply specialist (retired); **Jon Lea**, DCO supervisor, (retired); **Rick McClure**, snow survey supervisor (retired); **Sheila Strachan**, hydrologist, Portland, OR; **Jeri Lynn Ward**, statistical assistant, Bozeman, MT; and **Melissa Webb**, assistant DCO supervisor, Portland, OR, provided assistance with edits and revisions.

The chapter was finalized under the guidance of **Claudia C. Hoefft**, national hydraulic engineer, Washington, DC.

Editorial assistance was provided by **Wendy Pierce**, illustrator, and **Suzi Self**, editorial assistant, NRCS National Geospatial Management Center, Fort Worth, TX.

Chapter 8

Standards and Specifications

Contents	622.0800	Introduction	8-1
	622.0801	Documentation Files for Standards and Specifications	8-1
	622.0802	Standards and Specifications	8-2
	622.0803	Standard Drawings	8-2
	622.0804	References	8-5
	Appendix 8A	Data Collection Sites	
	Appendix 8B	Equipment	
	Appendix 8C	Sensors	
	Appendix 8D	Data Management	
	Appendix 8E	System Performance	
	Appendix 8F	Forecasting	
	Appendix 8G	Standard Drawings	

Figures

Figure 8B-1	Federal Snow Sampler set	8B-3
Figure 8C-1	Standard depths for sensing devices	8C-25
Figure 8G-1	Standard drawings	8G-3
Figure 8G-2	Federal snow sampler	8G-4
Figure 8G-3	SNOTEL data site sign	8G-14
Figure 8G-4	SNOTEL shelter	8G-15
Figure 8G-5	Snow course marker	8G-28
Figure 8G-6	Storage precipitation gage	8G-29

Tables

Table 8-1	Alphabetical listing of standards and specifications	8-3
Table 8-2	Standards and specifications by category	8-4
Table 8-3	Standard drawings	8-5
Table 8B-1	Battery specifications	8B-8
Table 8B-2	Data logger specifications	8B-11
Table 8B-3	Receiver specifications	8B-15
Table 8B-4	Transmitter specifications	8B-16
Table 8C-1	Air temperature sensor mounting height	8C-3
Table 8C-2	Mounting height of relative humidity sensor based on maximum snow depth	8C-13
Table 8C-3	Solar radiation sensor mounting height	8C-29
Table 8C-4	Mounting height of wind speed and wind direction sensors based on maximum snow depth	8C-41
Table 8D-1	Example 1: Standard SNOTEL with four soil moisture sensors	8D-4
Table 8D-2	Example 2: Standard SNOTEL with five soil moisture sensors and a fire weather sensor	8D-5
Table 8G-1	Standard drawings	8G-1

622.0800 Introduction

The standards and specifications included in this handbook pertain to the Snow Survey and Water Supply Forecasting (SSWSF) Program work administered by U.S. Department of Agriculture (USDA), Natural Resources Conservation Service (NRCS). These standards and specifications were developed to:

- prevent omission of essential elements
- prevent inclusion of extraneous materials
- provide a uniform basis for interpretation and water supply forecasting activities
- ensure consistency and uniform quality of NRCS work relative to the SSWSF Program

NRCS standards and specifications found in the National Handbook of Conservation Practices (NHCP) and the National Engineering Handbook, Part 642, Specifications for Construction Contracts (NEH642), may also be applicable to SSWSF Program work, particularly data collection site installations.

The information in this chapter supersedes information in USDA Soil Conservation Service, National Engineering Handbook, Section 22, Snow Survey and Water Supply Forecasting.

These standards and specifications will be modified whenever it appears appropriate to do so. Suggestions for changes, additions, deletions, or corrections should be submitted to the Director, National Water and Climate Center (NWCC).

Trade names are used in the publication solely for the purpose of providing specific information. Mention of a trade name does not constitute a guarantee of a product by the USDA, nor does it imply an endorsement by the Department over other products not mentioned.

622.0801 Documentation Files for Standards and Specifications

A documentation file for each of the SSWSF Program standards and specifications is maintained at the NWCC. This file includes material relevant to the standard, including why and how specific technology became a part of the standard, and the rationale for each criterion and consideration. Each file includes:

- a summary of changes from one version of the standard or specification to the next
- a history of the development of the standard or specification, including a log of past decisions to document why comments were or were not incorporated into revisions as part of the review process
- copies of technical sources and appropriate literature cited in the standards or specifications to document criteria and technological changes.

All standards are to be periodically reviewed and adjustments or modifications made as necessary.

By maintaining this documentation, the rationale or criteria used in setting the standard or developing the specification can be tracked. As a result, this documentation is an invaluable record in addressing questions raised within the NRCS, by the public, or by NRCS partners, concerning the science and rationale used setting the standards and defining the appropriate specifications.

States should also maintain documentation files on standards where the State adds criteria to the standard or makes criteria more stringent than the national criteria.

622.0802 Standards and Specifications

The SSWSF standards and specifications are divided into six categories:

- data collection sites
- equipment
- sensors
- data management
- performance
- forecasting

Appendices A through F contain a description of each category along with the individual standards and specifications.

Table 8–1 contains an alphabetical listing of all current standards and specifications in this chapter.

Table 8–2 contains a listing of all of the standards and specifications in this chapter according to appendix category.

622.0803 Standard Drawings

A number of standard drawings are provided for equipment and other items used in snow data collection. These standard drawings are found in appendix 8G. CAD drawings for many of the drawings are available from the NWCC on request.

Table 8–3 contains an alphabetical listing of the standard drawings in appendix 8G.

Table 8-1 Alphabetical listing of standards and specifications

Title	Appendix / Category
Aerial Marker	Appendix 8A / Data Collection
Air Temperature Sensor	Appendix 8C / Sensors
Barometric Pressure Sensor	Appendix 8C / Sensors
Data Collection Site Location	Appendix 8A / Data Collection
Data Management	Appendix 8D / Data Management
Federal Snow Sampler Set	Appendix 8B / Equipment
Pressure Transducer	Appendix 8C / Sensors
Relative Humidity Sensor	Appendix 8C / Sensors
SNOTEL Antenna	Appendix 8B / Equipment
SNOTEL Battery Power System	Appendix 8B / Equipment
SNOTEL Data Logger	Appendix 8B / Equipment
SNOTEL Data Site Sign	Appendix 8A / Data Collection
SNOTEL NEMA Enclosure	Appendix 8B / Equipment
SNOTEL Radio	Appendix 8B / Equipment
SNOTEL Remote Station Performance	Appendix 8E / System Performance
SNOTEL Shelter	Appendix 8B / Equipment
SNOTEL Site Layout and Station Maintenance	Appendix 8A / Data Collection
SNOTEL Solar Panel	Appendix 8B / Equipment
SNOTEL Systemwide Performance	Appendix 8E / System Performance
SNOTEL Tower	Appendix 8B / Equipment
Snow Course	Appendix 8A / Data Collection
Snow Course Marker	Appendix 8A / Data Collection
Snow Depth Sensor	Appendix 8C / Sensors
Snow Pillow Snow Water Equivalent (SWE) Sensor	Appendix 8C / Sensors
Soil Moisture and Soil Temperature Sensor	Appendix 8C / Sensors
Solar Radiation Sensor	Appendix 8C / Sensors
Station and Sensor Metadata Management	Appendix 8D / Data Management
Storage Precipitation Gage	Appendix 8C / Sensors
Tipping Bucket Precipitation Gage	Appendix 8C / Sensors
Water and Climate Information System Management	Appendix 8D / Data Management
Water Supply Forecast	Appendix 8F / Forecasting
Wind Speed and Wind Direction Sensor	Appendix 8C / Sensors

Table 8–2 Standards and specifications by category

Appendix / Category	Title
Appendix 8A / Data Collection Sites	Aerial Marker
	Data Collection Site Location
	SNOTEL Data Site Sign
	SNOTEL Site Layout and Station Maintenance
	Snow Course
Appendix 8B / Equipment	Snow Course Marker
	Federal Snow Sampler Set
	SNOTEL Antenna
	SNOTEL Battery Power System
	SNOTEL Data Logger
	SNOTEL NEMA Enclosure
	SNOTEL Radio
	SNOTEL Shelter
SNOTEL Solar Panel	
Appendix 8C / Sensors	SNOTEL Tower
	Air Temperature Sensor
	Barometric Pressure Sensor
	Pressure Transducer
	Relative Humidity Sensor
	Snow Depth Sensor
	Snow Pillow Snow Water Equivalent (SWE) Sensor
	Soil Moisture and Soil Temperature Sensor
	Solar Radiation Sensor
	Storage Precipitation Gage
Tipping Bucket Precipitation Gage	
Appendix 8D / Data Management	Wind Speed and Wind Direction Sensor
	Data Management
	Station and Sensor Metadata Management
Appendix 8E / System Performance	Water and Climate Information System Management
	SNOTEL Remote Station Performance
Appendix 8F / Forecasting	SNOTEL System-wide Performance
	Water Supply Forecast

Table 8-3 Standard drawings

Title
Aerial Marker
Federal Snow Sampler
SNOTEL Data Site Sign
SNOTEL Shelter
Snow Course Marker
Storage Precipitation Gage

622.0804 References

- U.S. Department of Agriculture, Natural Resources Conservation Service. 2011. National Engineering Handbook, Part 622, Snow Survey and Water Supply Forecasting Handbook. Washington, DC.
- U.S. Department of Agriculture, Soil Conservation Service. 1984. Agriculture Handbook No. 169, Snow Survey Sampling Guide. Washington, DC.
- U.S. Department of Agriculture, Soil Conservation Service. 1979. Field manual for research in agricultural hydrology. Agriculture Handbook No. 224, Remote hydrological monitoring and data collection station standards for data validation and editing. Washington, DC.
- U.S. Department of Agriculture, Soil Conservation Service. 1972. National Engineering Handbook, Section 22, Snow Survey and Water Supply Forecasting. Washington, DC.

Data collection site standards and specifications deal specifically with selection of data collection site locations, their layout, and required maintenance of those sites. These standards focus on ensuring that site locations for hydrometeorological monitoring stations reflect the hydrological and/or meteorological aspects of the target area to ensure data quality and consistency of data collected for snow survey and water supply forecasting purposes.

This is a list of the standards and specifications in this appendix.

- Aerial Marker
- Data Collection Site Location
- SNOTEL Data Site Sign
- SNOTEL Site Layout and Station Maintenance
- Snow Course
- Snow Course Marker

Aerial Marker

Definition

Aerial marker sites are used by NRCS to collect data manually from remote and high-elevation, mountainous regions considered too inaccessible to access by ground during the snow season.

Purpose

The purpose of this standard is to provide guidance on site selection, layout, installation, and maintenance of aerial markers in order to ensure data quality and consistency of snow depth data collected by NRCS using aerial markers.

Conditions where this standard applies

This standard applies to all aerial marker sites installed, operated, or maintained by NRCS.

Criteria

Site selection

- The most important consideration in site selection is safe aircraft operations. There must be room for a safe, low-elevation approach and recovery. There must also be plenty of turnaround room for additional fly-by observations.
- The ideal site for an aerial marker site is a small clearing (approximately 120- to 160-ft diameter circle) of a quarter- to a half-acre in size. The size of the clearing should depend on the height of the vegetation.
- Avoid locations where snow scouring, loading, or drifting occur as the measurements are likely to be more associated with how much the wind blows rather than how much snow falls.
- Sites should be near terrain features that are readily distinguishable in order to be easily located from the air.

Layout

- In the case of tall trees (80 to 100 ft) on a large site of a 200 foot or more diameter circle (greater than a half acre), the marker could be located anywhere in the opening.
- In a smaller opening of a circle 100 feet in diameter (less than 1/4 acre), the marker may need to be located near one edge to have an adequate, clear window view for the aerial observation. In the case of sparse tree growth, these considerations may not be necessary.
- At a chosen site, the specific spot to place the marker should be as smooth and level as possible, avoiding high spots, low spots, and bumpy, undulating ground. The area of consideration here is a 4- to 5-foot diameter circle in the center of which the aerial marker is placed.
- Vegetation growth should be removed to ensure the spot is as flat and smooth as possible. Any vegetation within approximately 12 feet of the marker should be cut back.

Installation

- Installation and maintenance must be performed by the NRCS staff or other competent personnel assigned by NRCS to perform the work.
- The hole dug to install the marker should be as small as possible to ensure the marker remains secure once installed.
- The hole must be dug at least 24 inches deep, or deep enough to provide adequate support for the aerial marker when the foundation is complete. Take measurements once the marker is set in the hole and backfilled, and

soil/rocks are tamped in as firmly as possible. Make the final measurement from ground surface to the middle of the first orange crossbar and record the measurement. If this measurement is not exactly 24 inches, add soil to the area to zero the correction factor. If not, bring in sand, gravel, etc. and make it a zero correction, or the difference becomes a permanent adjustment (correction factor). Usually this correction factor will be plus or minus 1 inch. Apply the correction factor to the final reading.

- Ensure the crossbars are placed parallel to the line of flight, or in an orientation determined to be easiest to see from the flight path of passing aircraft.
- Fill the hole with concrete. Ensure the marker is vertical. It may need to be supported until the concrete has set up enough to support the marker on its own.
- Markers may settle or heave by an inch over the first winter before stabilizing. Another measurement must be taken the next summer season to determine any possible further adjustment to the correction factor.

Field maintenance

- The data collection office (DCO) must maintain a log of scheduled and completed maintenance for each aerial marker.
- Maintenance for each aerial marker will be as scheduled by the DCO and should be performed as needed.
- The ground surface around each sampling point must be cleared for a distance of approximately 12 feet in all directions. Clearing includes all rock, fallen trees, stumps, and brush that are greater than 6 inches in height.
- All trees around each aerial marker a distance of 25 to 30 feet must be cleared to prevent hazardous flying and sight conditions for the aircraft. Clearing of trees beyond 30 feet must be coordinated with the DCO and landowner.
- The ground surface immediately beneath the marker must be checked for erosion or other disturbance that may change the actual height aboveground of the marker. If possible, repair any disturbance by filling in or excavating back to its original height. If the surface cannot be brought back to its original level, then make adjustments to the correction factor.
- The height of marker must be measured to ensure that its original measurements above the ground surface have not changed.
- Cross boards and angle braces must be painted red or orange when needed, so that the marker is completely protected and brightly colored for easy viewing.
- Damaged cross boards, angle braces, or signage must be repaired or replaced.
- Livestock are attracted to aerial markers; often rubbing against them. Ensure the construction material can withstand this activity. Often, 2- by 6-inch pressure-treated wood or a quarter-inch steel plate can be used on the lower portion of the marker. Livestock also tend to excavate the soil material from around the marker. Periodic remeasurement may be required to calculate the snow depth correctly.

Considerations

Site selection of aerial markers must be done according to site location standards and techniques described in National Engineering Handbook, Part 622, Chapter 3, Site Selection (NEH622.03).

Plans and specifications

Plans and specifications associated with all maintenance procedures considered for use at aerial markers must be in keeping with this standard. A standard drawing of an aerial marker is in appendix 8G.

Responsibilities

The data collection office (DCO) or water supply specialist is responsible for installation, maintenance, and proper data collection at aerial markers in its State. Data collection standards must be periodically reviewed by the NWCC and adjustments or modifications made as needed.

References

U.S. Department of Agriculture, Natural Resources Conservation Service. 2011. National Engineering Handbook, Part 622, Snow Survey and Water Supply Forecasting Handbook. Washington, DC.

Data Collection Site Location

Definition

A data collection site is a physical site, such as a snow course, a snow telemetry (SNOTEL) station, or aerial marker, at which hydrometeorological data are collected. Site location refers to the actual physical location of the site in the watershed.

Purpose

The purpose of this standard is to ensure that site locations for hydrometeorological monitoring stations reflect the hydrological and meteorological aspects of the target area to ensure data quality and consistency of data collected for snow survey and water supply forecasting purposes, in order to enhance resource management in a watershed, eco region, major land resource area, or land resource unit (LRU)/common resource area (CRA).

Conditions where this standard applies

This standard applies to all hydrometeorological monitoring sites, including manually measured snow courses and aerial markers, as well as SNOTEL stations installed, operated, or maintained by NRCS.

Criteria

- The site selected must satisfy the purpose of the site and be representative of the area being monitored including topography, geology, hydrology, and soils.
- Topographic, geologic, hydrologic, and soil conditions at the site must be satisfactory for site stability and construction.
- The immediate area of site must be protected from degradation impacting the site's performance or adversely affecting site longevity.
- All aspects of the site including vegetation, soils, geology, and aesthetics must be described, documented, and considered in the location plan and installation.
- Site selection must involve the assigned National Water and Climate Center forecast hydrologist for the watershed being monitored or the National Water and Climate Center resource conservationist.
- The district conservationist covering the area where installation is anticipated must be notified and kept informed on all SNOTEL installations in the area.
- When possible, stations should be located on Federal, State, county, or university lands or on lands owned by sponsors to ensure long-term use of the land for monitoring purposes. When it is not possible to locate stations on this type of land, consideration should be given to locating the station on the property of soil and water district landowners who are cooperators with NRCS.
- Site selection must meet landowner and sponsor requirements and may require special-use permits or meet NEPA requirements before construction.
- When selecting a suitable location, consideration of station security must be included. Generally, stations should not be located near public roads or trails.
- The specific purpose of the site must be identified and documented using the classifications outlined in NEH622.03 appendix A.
- All stations must be located far enough from obstructions to provide a minimum of 30 degrees of clear skies above the instrument designed to measure precipitation in any form.

- If snow-water content is a consideration, stations must be placed so that they are representative of the hydrological and meteorological aspects of the area being monitored.
- No stations must be located under or within 200 feet of high-voltage power lines. Power lines can be extremely dangerous to work around and all attempts to avoid contact with the lines should be made. Also, power lines closer than 200 feet have a very high potential for RF interference, which hinders optimum performance.
- Gently sloping areas are preferred. If snow-water content is of importance, slopes should not exceed 10 percent.
- The station should not be located in a drainage area where natural drainage of the surrounding area would adversely affect soil moisture measurements or result in standing water.
- If soil moisture and temperature sensors are installed, complete soil pedon characterization must be described, samples (including bulk density samples) must be taken, and lab analysis must be done at the National Soil Laboratory.
- Access requirements must be defined specifically in advance of installation. Access requirements for individual sites must become part of the overall access plans for the watershed, conservation district, service center, and State where the site is located.
- The visual impact of a potential site must be reviewed from an external and internal perspective. The site impact must be analyzed from two distances, one away from the site looking in and one at the site looking out. A photographic record of the site must be kept, with at least one image from the external views, and a minimum of four images of the internal view covering the four cardinal directions.

Considerations

Protection of the vegetative and geologic integrity of the site must be considered in site location and installation. Protective cover of vegetation must be maintained as necessary to meet landowner requirements. Site vegetation needs to be maintained as close as possible to conditions as they existed when the site was installed. If no landowner restrictions exist, then the vegetative cover should be established according to Conservation Practice Standard No. 342, Critical Area Planting, found in the National Handbook of Conservation Practice Standards (NHCP).

The sites selected under this standard must comply with applicable local, State, and Federal laws, rules, and regulations. All required permits must have been obtained before construction is started.

Responsibilities

The NRCS data collection office (DCO) is responsible for proper documentation of site conditions at hydrometeorological data collection stations. This information must be updated and reviewed as needed.

References

U.S. Department of Agriculture, Natural Resources Conservation Service. 2011. National Engineering Handbook, Part 622, Snow Survey and Water Supply Forecasting Handbook. Washington, DC.

U.S. Department of Agriculture, Natural Resources Conservation Service. 2013. Conservation Practice Standard No. 342, Critical Area Planting, National Handbook of Conservation Practice Standards.

SNOTEL Data Site Sign

Definition

The SNOTEL data site sign is a sign mounted on the SNOTEL shelter used to inform the public of the purpose of the station and who is responsible for maintaining it.

Purpose

The purpose of this standard is to describe the requirements for SNOTEL data site signs to ensure consistent signage at SNOTEL data collection sites installed, maintained, or operated by NRCS.

Conditions where this standard applies

This specification applies to all SNOTEL data site signs to be procured for use at NRCS automated data collection sites.

Criteria

- Must be made of 16-gauge steel plate or similarly durable material.
- Must be painted in accordance to current standard design and color.
- Must be 12- by 12-inches square.
- Must contain design and lettering consistent with the standard drawing in NEH622.08 appendix G.

Installation

- Must be securely mounted onto the “front” of the SNOTEL shelter at eye level or a height above the deepest expected snow depth.

Maintenance

- SNOTEL signs must be inspected annually to ensure they are highly visible and legible.
- Signs in poor condition must be removed and replaced with new signs.

Responsibilities

The NRCS data collection office (DCO) is responsible for installing and maintaining SNOTEL signs in its region.

Plans and Specifications

Plans and specifications associated with all SNOTEL signs considered for use at NRCS automated data collection sites must be in keeping with this standard. A standard drawing for this sign is in appendix 8G (NEH 622.08 G).

References

U.S. Department of Agriculture, Natural Resources Conservation Service. 2011. National Engineering Handbook, Part 622, Snow Survey and Water Supply Forecasting Handbook. Washington, DC.

SNOTEL Site Layout and Station Maintenance

Definition

Snow telemetry (SNOTEL) stations are used by NRCS to collect data from remote, mountainous regions, often at very high elevations. Site layout refers to the physical relationship of individual station components to each other and to the natural site conditions including elevation, vegetation, and other natural features. Maintenance and calibration of these remote data collection stations ensures valid data measurements, and valid data storage and transmission from the sensors associated with the SNOTEL network.

Purpose

This standard defines the relation of SNOTEL station components to each other and to existing site features including elevation, vegetation, and other natural features, and describes maintenance and calibration requirements at SNOTEL stations within the context of the natural site environment in order to:

- ensure the best data collection from the various sensors.
- ensure data quality and consistency of data collected for snow survey and water supply forecasting purposes.
- minimize the number of unexpected site visits due to site interference from plants or animals.
- maintain the appearance and structural integrity of the station.

Conditions where this standard applies

This standard applies to all SNOTEL stations installed, operated, or maintained by NRCS.

Criteria

Layout and installation

The minimum area for a station must be 10 by 10 feet for a single-tower installation and 20 by 20 feet for a two-tower installation, including a meteorological and transmit tower. A minimum of 50 by 50 feet is required for an installation requiring a snow pillow. Additional space may be required if the standard instrument shelter is included in the installation.

Snow pillow

- The snow pillow is the primary sensor and must be the first to be located. All other sensors and the electronics shelter are relational to the pillow.
- Pillow fluid manometer level in the shelter should be between 10 and 20 inches, except in rare cases due to terrain. Information on installation of the snow pillow is found in the Snow Pillow (Snow Water Equivalent Sensor) standard.
- There must be a clear sky window of at least 30 degrees in all directions from the snow pillow sensor. Some forest clearings may not meet this criterion. If this is the case, notes must be made in the metadata of this restriction.

Precipitation gage

- The precipitation gage location must be as close to the shelter as practical. Information on installation of precipitation gages is in the Storage Precipitation Gage standard and the Tipping Bucket Precipitation Gage standard.
- There must be a clear sky window of at least 30 degrees in all directions from the precipitation gage.

Tower

- The meteorological tower must be located directly adjacent to the pillow, at a maximum of 2 feet from the edge of the snow pillow such that the depth sensor can read snow depth directly over the pillow.
- One combined meteorological/antenna tower or two individual towers, one meteorological and one antenna per site, are acceptable. If two towers are used, the preferred location for the antenna tower is attached to the shelter or where maximum solar exposure is available. Information on installation of meteorological and antenna towers is in the SNOTEL tower standard.

Shelter

- Shelter location must be as close as practical to the pillow and precipitation gages and at an elevation where the pillow and precipitation manometers will read between 10 and 20 inches.
- The shelter must not interfere with operation of the site sensors. The shelter distance should not be greater than 50 feet from sensors, except in rare instances, and should be located downwind of the prevailing wind direction.
- Refer to the SNOTEL shelter standard for information on installation of the shelter.

Soil moisture sensors

- Soil moisture sensors must be located in the most representative area, accounting for the following:
 - topography—not in depressions, channels, or other water-collecting areas
 - away from the influence of the shelter, both shadow and roof runoff
 - away from large vegetation if possible
 - away from the influence of the pillow pad and precipitation gage
 - mineral soil
 - away from areas of human disturbance such as compaction, digging, etc.
- Refer to the Soil Moisture and Soil Temperature Sensor standard for information on installation of soil moisture sensors.

Documentation

- Vegetation extent, proximity, and height must be documented onsite after installation is complete. At a minimum, photos of cardinal directions must be taken for the following conditions:
 - looking from a distance 50 to 100 feet to the site
 - looking from the site to a distance
 - looking from a distance 50 to 100 feet to the pillow
 - looking from the pillow to a distance
- If practical, aerial photos at 100-foot elevation or higher than the site surrounding vegetation are desirable. Appropriate photo documentation or maps and figures must be prepared and updated or repeated every 5 years.
- Mileage logs and directions must be created for each site. GPS coordinates must be taken at the pillow in the NAD83 system at ground truth sample point number 1. If there is not a pillow, take the coordinates at the tower base.
- Site sketch maps must be made to identify location of structures, vegetation, and obstructions from a specific location (preferably from the shelter front door) with direction and distance to each.

-
- Metadata must be collected for all sensors and equipment making up the station. Sensors will require the height-aboveground measurements, manufacturer, make, model, and serial number. Refer to the appropriate sensor standards for more information on recordkeeping for individual sensors.
 - Each sensor must have photo documentation at the time of installation clearly showing the individual sensor installation, plumbing, cable lines, and site layout.
 - Maintenance must be performed by the NRCS staff or other competent personnel assigned by NRCS.

Field maintenance

- Field maintenance and calibration procedures must be done at each scheduled site maintenance visit or at least once a year.
- Field calibration must be done following methods and specifications described in NEH622.05, Maintenance and Calibration.
- All towers must be inspected for safety, damage, and wear at each visit.
- Vegetation must be prevented from encroaching on the site on the ground and overhead. Changes in canopy must be documented.
- Inspect for damage from varmints or insects and take measures to prevent such damage.
- All components or structures must be maintained in a neat and orderly appearance.

Considerations

Layout and installation

- Refer to NEH622.03, Site Selection, for information regarding general watershed placement and the primary reason for the station.
- Keeping the overall footprint of the site as small as possible is beneficial for two reasons:
 - better data quality. When working with fluids in various types of tubing, the shorter the distance to the manometer and pressure transducer, typically the less data fluctuation is exhibited
 - smaller environmental impact
- Other factors to consider in the general site layout assessment are:
 - extent of material/soil excavation and vegetation removal needed
 - precipitation gage and snow pillow location, such that there is the greatest clear sky view while minimizing wind effects
 - shelter location such that the pillow and precipitation manometer heads are sufficient to provide at least 10 inches above the pressure transducer, typically 10 to 20 inches above the floor
 - large rocks, bedrock, large trees, or other complicating factors that may dictate component locations
 - station visibility
 - proximity to steeper slopes that could cause creep problems
 - minimizing potential wind impacts
- Overall site visibility from access roads must be as small as possible to reduce the potential of vandalism.
- Landowner criteria.

Maintenance

- Environmental conditions at remote sites are highly variable and uncontrollable. Extreme cold, heat, wind, rain, snow, and ice may cause unexpected reactions from the sensor. Unusually harsh conditions may require that maintenance and calibration verification be performed more often than specified to ensure data quality.
- Inconsistencies in electronic components and mounting configurations may affect the performance of a sensor. Every effort should be taken to recognize any inconsistency that might account for performance problems, and eliminate the inconsistency when possible.
- Refer to the appropriate component standards for specific operation and maintenance requirements for individual sensors and other SNOTEL site components.

Plans and specifications

Plans and specifications associated with all maintenance procedures considered for use at SNOTEL stations must be in keeping with this standard.

Operation and maintenance

The NRCS data collection office (DCO) is responsible for maintaining all SNOTEL stations in its associated region. Maintenance plans must be developed. Plans must be periodically reviewed and adjustments or modifications made as needed.

- Maintenance records must be kept for all field and shop procedures.
- Records must be maintained on official data site form or site ledger and entered in central database.
- Records of maintenance must be kept in the data collection office. Records must be maintained for the life of the data collection site.

Responsibilities

The NRCS DCO is responsible for proper data collection at all SNOTEL stations in its associated region. Data collection standards must be periodically reviewed and adjustments or modifications must be made as needed.

References

U.S. Department of Agriculture, Natural Resources Conservation Service. 2011. National Engineering Handbook, Part 622, Snow Survey and Water Supply Forecasting Handbook. Washington, DC.

Snow Course

Definition

Snow courses are manual data collection sites consisting of a selected line of sample points along measured intervals used by NRCS to collect data from remote, high-elevation, mountainous regions. The number of sample points, intervals length, and the total length ranges depending on site conditions and uniformity of snow cover.

Purpose

The purpose of this standard is to define the components of manual data collection snow course sites in relation to existing natural site features including elevation, vegetation, and other features, in order to ensure data quality and consistency.

Conditions where this standard applies

This standard applies to all manual data collection snow courses installed, operated, and maintained by NRCS.

Criteria

Installation and maintenance must be performed by NRCS staff or other competent personnel assigned by NRCS to perform the work. Field procedures should be done during routine site maintenance visits to snow courses (usually scheduled on an annual basis), during unscheduled site visits, or when upkeep is visibly needed.

Installation

- Sampling points along the snow course are established along a selected line or group of connected lines, of marked length in snow accumulation areas. Sample points are typically at intervals of 25, 50, or 100 feet, but may be at almost any interval. Large obstructions on or near the line may require increasing or decreasing the interval for one or more sampling points.
- 10 to 20 sampling points are recommended for a new course, but the number varies with each snow course. After the data record has been established that provides a clear correlation to streamflow, analysis may be done to reduce the number of points. Approximately five sampling points should be selected for a permanent course.
- Individual sampling points may be marked to facilitate locating the point each time it is sampled. If not marked, sampling points are located by measuring from the end marker each time the course is measured.
- The end points of the line and angle points must be permanently marked with a standard snow course marker. Refer to Snow Course Marker standard drawing, appendix G.
- The marker should be mounted on a steel pipe or fence post and set in concrete. Trees may be used to mount markers when available.
- Standard markers must extend above the deepest anticipated snow.
- The ground surface around each sampling point must be cleared of all rock, fallen trees, stumps, and brush greater than 6 inches in height for a distance of 6 feet in all directions.
- Photos from the north, south, east, and west of the site (showing the canopy) must be taken.

Field maintenance

- The NRCS DCO or water supply specialist (WSS) must maintain a log of scheduled and completed maintenance for each site.

-
- Maintenance for each snow course will be scheduled by the NRCS DCO or WSS and must be performed annually.
 - Snow course markers that have been damaged or missing must be replaced.
 - The ground surface around each sampling point must be cleared of all rock, fallen trees, stumps, and brush greater than 6 inches in height for a distance of 6 feet in all directions.
 - Trees must be kept from growing over and changing the historical canopy, and must be cleared if allowed by the USFS special use permit. Growth of the canopy may change the way the site catches the snow, which can skew the data set.
 - The site must be rephotographed taking photos from the north, south, east, west, and showing the canopy.
 - Recommendations for additional maintenance or longer-term maintenance must be recorded and submitted to the NRCS DCO or WSS.

Considerations

Site selection of manual data collection snow courses must be done according to site location standards and techniques described in NEH622.03, Site Selection.

Plans and specifications

Plans and specifications associated with all maintenance procedures considered for use at snow courses must be in keeping with this standard.

Operation and maintenance

- The NRCS DCO or WSS is responsible for maintaining all snow courses. Maintenance plans must be developed. Plans must be periodically reviewed, and adjustments or modifications must be made as needed.
- Maintenance records are the responsibility of the NRCS DCO or WSS.
- Maintenance records must be kept for all field and shop procedures.
- Records must be maintained on a data site form or the site ledger and must be entered in the central database.
- Records must be maintained for the life of the data collection site.

Responsibilities

The NRCS DCO or WSS is responsible for proper data collection at all snow courses in its State.

The NRCS National Water and Climate Center (NWCC) is responsible for developing data collection standards that must be periodically reviewed and adjusted or modified as needed.

References

U.S. Department of Agriculture, Natural Resources Conservation Service. 2011. National Engineering Handbook, Part 622, Snow Survey and Water Supply Forecasting Handbook. Washington, DC.

Snow Course Marker Sign

Definition

The snow course marker is a sign indicating the beginning and end of a snow course. The sign also indicates any sample points where there is a change in direction for the next sample point in the course.

Purpose

The purpose of this standard is to describe the requirements for snow course marker signs to ensure consistent signage at manual data collection sites installed, maintained, or operated by NRCS.

Conditions where this standard applies

This specification applies to all snow course marker signs to be procured for use at NRCS snow courses.

Criteria

- Must be constructed of one quarter-inch Masonite® or similar material.
- Must be painted yellow with black lettering.
- Must be 16- by 16-inches square.
- Must contain design and lettering consistent with the standard drawing in NEH 622.08 appendix G.

Installation

- Signs must be permanently mounted, preferably on 2-inch galvanized pipe at a height above the deepest expected snow depth. In deep snow conditions, a suitable tree may also be utilized. See NEH622.04, Site Installation.

Maintenance

1. Snow course signs must be inspected annually to ensure they are highly visible and legible.
2. Signs in poor condition must be removed and replaced with new signs.

Responsibilities

The NRCS data collection office (DCO) or water supply specialist (WSS) is responsible for installing and maintaining snow course marker signs in their state.

Plans and specifications

Plans and specifications associated with all snow course marker signs considered for use at NRCS snow courses must be in keeping with this standard. A standard drawing of a snow course marker is in appendix 8G (NEH 622.08 G).

References

U.S. Department of Agriculture, Natural Resources Conservation Service. 2011. National Engineering Handbook, Part 622, Snow Survey and Water Supply Forecasting Handbook. Washington, DC.

Equipment standards and specifications provide the minimum requirements for equipment used in collection of data, along with the necessary maintenance and calibration of that equipment.

This a list of the standards and specifications for equipment.

- Federal Snow Sampler Set
- SNOTEL Antenna
- SNOTEL Battery Power System
- SNOTEL Data Logger
- SNOTEL NEMA Enclosure
- SNOTEL Radio
- SNOTEL Shelter
- SNOTEL Solar Panel
- SNOTEL Tower

Federal Snow Sampler Set

Definition

A Federal Snow Sampler is a device designed to measure snow water equivalency (SWE) by weighing the tube and its snow content on a tubular spring scale (fig. 8B-1).

Purpose

The purpose of this standard is to provide specifications for the Federal Snow Sampler used by NRCS to collect SWE data in order to ensure data quality and consistency of manually collected data.

Conditions where this standard applies

This standard applies to snow sampler sets used to collect SWE and snow depth data at data collection sites installed, operated, or maintained by NRCS.

Criteria

Snow sampling equipment

- Equipment must be constructed consistent with the standard drawings in NEH622.08 appendix 8G.
- Federal Snow Sampler tubing must be constructed from duraluminum.
- Tubing outside diameter must be one and three-quarter inches. Tubing inside diameter must be one and eleven-sixteenths inches.
- Tubing sections must be 30 inches long.
- Tubing sections must be marked at half-inch intervals.
- The first or lower section must have a steel cutter bit which is cold shrunk to fit the heated lower end of the section.

Figure 8B-1 Federal Snow Sampler set



- The cutter bit must have an inside diameter of 1.485 inches, which is about three-sixteenths of an inch smaller than the inside diameter of the tubing. This difference permits easier sampling and removal of the snow core.
- The tube sections are assembled by threaded couplings to lengths of 300 inches or more. The slots spaced alternately along the tube sections are provided for observing the length of the core sample. The weighing cradle that holds the snow tube is attached to a spring clip on the bottom of the tubular scales.
- The scales are in three sizes: for snow depths of 12.5 feet, up to 20 feet, and up to 30 feet. All scales weigh in ounces. Since the cutter point of the sampler cuts a snow core 1.485 inches in diameter, each ounce of core is equivalent to 1 inch of water.
- Spanner wrenches are used to unscrew the sections that may tighten in place when sampling. The driving wrench is clamped on the tube to drive it into deep, hard, compact snow and to cut through layers of ice. Specifications for spanner and driving wrenches are available from the NRCS National Water and Climate Center.

Shop maintenance and calibration

- The proper care and maintenance of snow survey tools is essential for reliable results. Clean, well-lubricated snow tubes and a sharp cutter can eliminate many difficulties in obtaining accurate samples. The most important part of this maintenance is to ensure the tube sections are covered with a thin coating of silicon lubricant or wax. A complete description of maintenance procedures is in NEH622.05, Maintenance and Calibration.
- A thorough cleaning and close inspection for damage that could affect the measurements must be done before and after each day of sampling.
- Applying silicone or waxing and polishing of the inside of the snow tubes must be done annually, or more often if needed.
- The cutter bit must be sharpened as needed.
- The spring balance must be cleaned and checked for calibration at least every 6 years.

Recordkeeping

Records must be kept of all the field and shop procedures, and must include the maintenance and calibration of each sensor by its serial number. Records must be maintained on official data site forms or ledgers and entered into the central database.

Plans and specifications

Plans and specifications for the manufacture and maintenance of snow samplers must be in keeping with this standard. All equipment must be constructed consistent with the standard drawings in appendix 8G (NEH 622.0802 G).

Maintenance

The NRCS data collection office (DCO) is responsible for maintaining and ensuring calibration of all Federal Snow Samplers in its region.

Responsibilities

The DCO is responsible for proper condition of Federal Snow Samplers in its associated region. Federal Snow Sampler standards must be periodically reviewed and adjustments or modifications must be made as needed.

References

U.S. Department of Agriculture, Natural Resources Conservation Service. 2011. National Engineering Handbook, Part 622, Snow Survey and Water Supply Forecasting Handbook. Washington, DC.

U.S. Department of Agriculture, Soil Conservation Service. 1984. Snow Survey Sampling Guide, Agriculture Handbook No. 169.

SNOTEL Antenna

Definition

Antennae are used at remote snow telemetry (SNOTEL) data collection sites to send and receive radio frequency (RF) signals containing SNOTEL commands and data. Antennae are ruggedly designed and constructed to withstand the severe winter conditions found in the high mountains of the western United States and in the arctic environment of Alaska. Antennae allow remote site transceivers to communicate with a master station, on a preset frequency, using meteor burst technology.

Note: Telemetry using nonmeteor burst technology is considered nonstandard and will not be addressed in this document.

Purpose

The purpose of this standard is to provide specifications and installation criteria for antennae to allow clear communication between remote site transceivers and master stations, to ensure data quality and consistency of data collected at SNOTEL stations installed, operated, or maintained by NRCS.

Conditions where this standard applies

This specification applies to all remote site antennae to be procured for use with 100-watt meteor burst transceivers and installed on SNOTEL sites installed, operated, or maintained by NRCS.

Criteria

General

- Antenna must be of YAGI-type construction.
- Antenna must be center mounted.
- Antenna boom must be fabricated from three-quarter inch, Schedule 40, 6061-T6 aluminum pipe to minimize wind-loading and snow buildup.
- Boom length for 5.0 dB types must not exceed 9.0 feet. Boom length for 7.0 dB types must not exceed 10.5 feet.
- Elements must be of double-wall construction to act as a vibration damper and to minimize the chance of failure due to wind-loading and snow buildup. Outer wall must be three-quarter-inch, seam-drawn, 6061-T6 aluminum tubing having a wall thickness of 0.049 inches. Inner wall must be of five-eighths inch, 6061-T6 aluminum tubing with a wall thickness of 0.058 inches.
- Each antenna must be finished with either an anodic coating of at least 0.0025 inch in thickness which conforms to MIL Specification 8625F, or an iridited coating providing equivalent (or better) protection.
- Antenna finished weight, including mounting hardware, must not exceed 25 pounds.
- Each antenna must be tuned to a transmit frequency of 41.61 MHz and a receive frequency of 40.67 MHz.
- The use of plastic mounting blocks for the attachment of the elements to the beam, or using blind or pop rivets as fasteners is unacceptable.
- Antenna must be horizontally polarized.
- VSWR at resonance must not exceed 1.5 to 1.
- Antenna must have a minimum 250-watt input rating.
- Impedance must be 50 ohms.

- The antenna coaxial cable connector must accept a PL-259, male, UHF connector, or Type N connector which terminates the coaxial cable.
- Components of the radiating element must be sealed as necessary, to prevent moisture penetration and reduce internal corrosion.
- Mounting hardware, brackets, U-bolts, and nuts must be treated to prevent corrosion.
- Antenna must meet or exceed all minimum Electronics Industries Association (EIA) standards.

Installation criteria

- Elements must separate from the boom to facilitate transport to remote sites. Crated dimensions must not exceed 5 by 6 by 85 inches.
- Antenna mounting hardware must be capable of mounting antenna to a tower leg or vertical mast having an outside diameter of from 1.250 to 2.375 inches.
- Mounting hardware must be constructed to facilitate a change in positioning, either up, down, or in rotation as local site conditions require.

Considerations

Environmental conditions at remote sites are highly variable and uncontrollable. Extreme cold, heat, wind, rain, snow, and ice may cause unexpected reactions from the antenna. Unusually harsh conditions may require maintenance checks to be performed more often than specified to ensure data quality.

Inconsistencies in electronic components and mounting configurations can affect the performance of sensors. Every effort should be taken to recognize any inconsistency that might account for performance problems, and eliminate the inconsistency when possible.

Plans and specifications

Plans and specifications associated with all antennae considered for use at SNOTEL stations must be in keeping with this standard.

Operation and maintenance

- Antenna must be checked annually for proper orientation and secure mounting.
- Coax connection must be checked annually.
- Maintenance and calibration records must be kept for all field and shop procedures.
- Records must be maintained on official data site form or site ledger and entered in central database.
- Records must be maintained for the life of the data collection site.

Responsibilities

The NRCS DCO is responsible for maintaining and ensuring calibration of all SNOTEL antennae in its associated region.

References

- Aerospace Specification Metals, Inc. 2011. Aluminum 6061-T6 Material Data Sheet.
- Electronic Industries Association. 2003. EIA RS-329B. Minimum Standards for Communication Antennas.
- EverySpec. 1993. Military specification: Anodic coatings for aluminum and aluminum alloys. MIL-A-8625F.
- U.S. Department of Agriculture, Natural Resources Conservation Service. 2011. National Engineering Handbook, Part 622, Snow Survey and Water Supply Forecasting Handbook. Washington, DC.

SNOTEL Battery Power System

Definition

This commercial item description contains the requirements for a minimum of 12-volt, 100 ampere-hour, sealed, lead-acid batteries, used to provide power to the remote site transceiver and data logger for snow telemetry (SNOTEL) stations.

Purpose

The purpose of this standard is to—

- Define the minimum requirements for the battery power system required to operate field instrumentation at SNOTEL sites.
- Ensure adequate power at remote SNOTEL stations for the purposes of recording (logging) and sending and receiving the data using the meteor burst network to ensure minimum data losses.
- Minimize the number of unexpected site visits due to power losses and battery failures.

Conditions where this standard applies

This specification applies to all remote site batteries to be procured for use at SNOTEL data collection stations installed, operated, or maintained by NRCS.

Criteria

Specifications

- Type: Must be a rechargeable, maintenance-free, lead-acid battery.
- Battery must operate in any orientation with no spillage of electrolyte.
- Battery terminals must be:
 - the nut-and-bolt type, capable of withstanding a current draw of 10 amps for 2 minutes
 - capped or protected in such a way as to prevent unintentional discharge before installation
 - potted where they extend through the external case
- The battery must be encased in an electrically nonconductive housing, with a case made of high-impact, acid-resistant plastic.
- At the terminals, the case must be marked “positive” or “negative” with permanent marking, such as raised or stamped symbols.
- Multicell, series-connected batteries must meet the following conditions:
 - be permanently joined together inside a suitable case that meets environmental requirements
 - have only two live terminals. Extra terminals must be sealed in a manner that will prevent corrosion and accidental discharge.
 - the connection between cells must not extend beyond the surface of the battery.
- Battery must be delivered in a 12-volt configuration so that no additional assembly is required by the receiving office to make it operational.
- The battery must have a self-sealing safety vent to prevent buildup of internal pressure.
- Must meet all the specifications in table 8B-1.

- On receipt from the vendor, the open circuit voltage must not be less than 12.60 volts.
- Label—Each battery must contain a permanently attached label located in a conspicuous position when the battery is in its normal operating orientation which, at a minimum, contains—
 - name and address of the manufacturer
 - battery model name or number
 - type of battery, such as sealed lead-acid, gelled type
 - voltage and amp-hour capacity of the battery
- Date of manufacture—Each battery must be stamped with the month and year that it is manufactured. If the date is coded by the manufacturer, the key to the code must be supplied by the manufacturer to the issuer of this specification.

Certification

The contractor must certify that the product offered meets the specifications of this description, and that the product conforms to the producer's own drawings, specifications, standards, and quality assurance practices, and is the same product sold on the commercial market. The government reserves the right to require proof of such conformance prior to the first delivery and, thereafter, as may be otherwise provided for under the provisions of the contract.

Table 8B-1 Battery specifications

Characteristic	Specification
Voltage	12–14 volts nominal
Load/capacity	Must not have open or high-resistance intercell connection nor short-circuit or low-capacity cells
Normal capacity	60–100 ampere-hours at the 20-hour current rate at 20 ± 2 °C to a cutoff voltage of 10.50–10.30 volts
Discharge	Must be able to recover from a deep discharge, down to 0 volts, at the 1-hour current rate
Cyclic operation	Must be capable of being fully charged within 24 hours using a dual-stage, constant voltage, temperature-compensated charging system with a C/10 current clamp, where C is the amp-hour capacity rating of the battery at the 20-hour current rate <ul style="list-style-type: none"> • Initial charging stage 14.40–14.70 volts • Final charging stage 13.50–13.80 volts
Float operation	Must be capable of accepting a continuous charging (float) voltage of 13.50–13.80 volts
Cycle life	Not less than 200 cycles with at least 80% depth of discharge per cycle. Cycle life will be considered ended when the battery capacity falls to 50% of its rated capacity
Standby battery life	Not less than 3 years at a float charge of 13.50–13.80 volts
Storage	Must be capable of withstanding periods of nonuse or storage at 25 °C for 6 months with no loss of ability to accept a full charge
Temperature range (°C)	Discharge: –40 to +60 Charge: –20 to +50

Packaging, packing, and marking

The batteries must be packaged in accordance with normal commercial practices that will ensure acceptance by common carriers and provide product protection against loss and damage during multiple shipments, handling, and storage.

Installation

- The batteries should be kept on the floor unless there is potential for flooding inside the building. In this case, a small shelf may be used to protect the batteries from the SNOTEL shelter with wiring coming into the building from the solar panels through well-sealed conduit. The wiring to and from the batteries should be secured well out of the way.
- Dielectric grease should be applied to the terminals for each battery.
- Banks of more than one battery should be wired in parallel to maintain the voltage output.
- The number of batteries used to operate the radio and the data logger can be determined by the site's solar and climate characteristics. With sufficient solar power, radios at some stations may operate with only one battery. Often it takes at least two batteries to maintain charge throughout the year. The data logger will generally operate all year with one battery.

Maintenance

- Battery charge must be checked annually.
- Terminals should be clean and free from corrosion.
- Battery must be replaced as soon as possible after any signs of degradation of performance or failure.

Considerations

Environmental conditions at remote sites are highly variable and uncontrollable. Extreme cold, heat, wind, rain, snow, and ice may cause unexpected reactions from the battery. Unusually harsh conditions may require maintenance checks to be performed more often than specified to ensure data quality.

Inconsistencies in electronic components and mounting configurations can affect the performance of batteries. Every effort should be taken to recognize any inconsistency that might account for performance problems, and eliminate the inconsistency when possible.

Plans and specifications

Plans and specifications associated with all batteries considered for use at SNOTEL stations must be in keeping with this standard.

Responsibilities

The NRCS DCO is responsible for proper installation and maintenance of batteries in its associated region.

References

U.S. Department of Agriculture, Natural Resources Conservation Service. 2011. National Engineering Handbook, Part 622, Snow Survey and Water Supply Forecasting Handbook. Washington, DC.

Data Logger

Definition

A data logger is a device used to store data collected from an automated snow telemetry (SNOTEL) station.

Purpose

The purpose of this standard is to provide shop and field maintenance and calibration criteria for data loggers to—

- ensure valid data measurements and data storage from sensors associated with the SNOTEL network
- ensure quality of data collected at SNOTEL stations
- reduce the potential for data losses
- minimize the number of unexpected site visits due to data logger failure

Conditions where this standard applies

This standard applies to all data loggers used on SNOTEL stations installed, operated, or maintained by NRCS.

Specifications

Must meet all the specifications in table 8B–2.

Table 8B–2 Data logger specifications

Characteristic	Specification
Operation	12V DC power system
Temperature	Operate in temperatures of -25°C to +50°C
Current Drain	~0.6 mA (sleep mode), 1 to 16 mA (w/o RS-232 communications), 17 to 28 mA (w/RS-232 communications)
A/D Bits	13
Scan Rate	100 Hz
Analog Channels	At least 16 single-ended (8 differential), individually configured
Analog Voltage Range	±5000 mV
Analog Voltage Accuracy	±(0.06% of reading + offset), 0° to 40°C
Measurement Resolution	To 0.33 µV
Switched Excitation Channels	3 voltage
Pulse Counters	At least 2
Control Ports	At least 2
Memory	2 MB Flash (operating system), 4 MB (CPU usage, program storage, and data storage)
Communication Ports	At least 1 I/O, 1 Parallel Peripheral
Protocols Supported	Modbus, DNP3, FTP, HTTP, XML, POP3, SMTP, Telnet, NTCIP, NTP, SDI-12, SDM

Criteria

Installation

The data logger must be securely mounted inside the National Electrical Manufacturers Association (NEMA) enclosure. The logger must be positioned so that all the connections are easily accessible to connect sensor wires, power, and communication cables.

Shop procedures should be performed on all data loggers as needed. Maintenance and calibration must be performed by the NRCS EMF shop. Data loggers that have been removed from the field must be shipped to NRCS EMF for repair. The NRCS EMF shop will be responsible for determining if the logger needs to be returned to the manufacturer for repair.

Field procedures should be done during routine site maintenance visits to SNOTEL stations, usually on an annual basis or during unscheduled site visits when the data is suspect.

Shop maintenance and calibration

Shop calibration checks must be performed as needed unless the sensor fails in the field.

For shop maintenance and calibration procedures refer to NEH622.05.

Field maintenance and calibration

Data loggers should be replaced with a currently calibrated unit as needed. Field maintenance and calibration verification procedures must be done at each scheduled site maintenance visit or once a year.

Field maintenance and calibration checks should be done following methods described in NEH622.05.

Considerations

Environmental conditions at remote sites are highly variable and uncontrollable. Extreme cold, heat, wind, rain, snow, and ice may cause unexpected reactions from the sensor. Unusually harsh conditions may require maintenance and calibration verifications be performed more often than specified to ensure data quality.

Inconsistencies in electronic components and mounting configurations may affect the performance of data loggers. Every effort should be taken to recognize any inconsistency that might account for performance problems, and then eliminate the inconsistency when possible.

Plans and specifications

Plans and specifications associated with data loggers considered for use at SNOTEL stations must be in keeping with this standard.

Responsibilities

The NRCS DCO is responsible for proper installation and maintenance of data loggers in its associated region.

References

U.S. Department of Agriculture, Natural Resources Conservation Service. 2011. National Engineering Handbook, Part 622, Snow Survey and Water Supply Forecasting Handbook. Washington, DC.

Campbell® Scientific. 2011. CR1000 Specifications and technical data.

SNOTEL NEMA Enclosure

Definition

The National Electrical Manufacturers Association (NEMA) enclosure provides protection to the remote site transceiver and data logger. This commercial item description contains the requirements for a NEMA Type 3 enclosure to house the electronic components for all SNOTEL stations.

Purpose

The purpose of this standard is to provide specifications and installation criteria for NEMA electronics enclosures to ensure data quality and consistency of data collected at SNOTEL stations installed, operated, or maintained by NRCS.

Conditions where this standard applies

This specification applies to all NEMA enclosures to be procured for use at remote SNOTEL stations.

Criteria

- NEMA enclosures must be a minimum of Type 3 enclosures for protection defined as follows:
 - dust-proof, rain-proof, sleet-proof, constructed for either indoor or outdoor use to provide a degree of protection to personnel against incidental contact with the enclosed equipment
 - provides a degree of protection against falling dirt, rain, sleet, snow, and windblown dust
 - will be undamaged by the external formation of ice on the enclosure
- A metal (aluminum or steel) backplate must be used to mount electronic components inside the enclosure.
- The enclosure may be constructed of steel, aluminum, or plastic.

Installation

- The NEMA enclosure must be mounted securely on the back wall of the SNOTEL shelter.
- Wiring coming into the building and through the bottom or side of the enclosure from the solar panels, batteries, antenna, and sensors must be through well-sealed conduit.
- One enclosure is required. Dimensions must be adequate to fit all components mounted on a back plate and allow easy access to the wiring panels. NRCS suggests a minimum of 24 inches tall, 24 inches wide, and 8 inches deep.
- The vendor must certify that the product offered meets the NEMA Type 3 classification.

Considerations

The size of the NEMA enclosure must be adequate to fit the required electronic components at a SNOTEL station, while leaving enough room to easily work around the components and allow all cables and wires to be kept out of the way.

The construction material and environmental rating of the NEMA enclosure may be determined by the particular climate or environmental factors that may cause corrosion, extreme dust, or other deterioration.

Plans and specifications

Plans and specifications associated with all NEMA enclosures considered for use at SNOTEL stations must be in keeping with this standard.

Responsibilities

The NRCS DCO is responsible for proper installation and maintenance of NEMA enclosures in its associated region.

References

National Electrical Manufacturers Association. 2008. Standards Publication 250–2008, Type 3, Enclosures for electrical equipment (1000 volts maximum).

U.S. Department of Agriculture, Natural Resources Conservation Service. 2011. National Engineering Handbook, Part 622, Snow Survey and Water Supply Forecasting Handbook. Washington, DC.

SNOTEL Radio

Definition

Radios are used by NRCS to transmit data collected at remote snow telemetry (SNOTEL) stations. Maintenance and calibration of radios ensures reliable and timely transmission of data from the sensors associated with the SNOTEL network.

Purpose

The purpose of this standard is to describe shop and field maintenance and calibration criteria for radios to—

- ensure reliable transmission of data from SNOTEL stations
- ensure quality of data collected at SNOTEL stations
- reduce potential for data losses

Conditions where this standard applies

This standard applies to all meteor burst radios installed on SNOTEL data collection stations installed, operated, or maintained by NRCS.

Note: Radios using nonmeteor burst technology are considered nonstandard and will not be addressed in this document.

Specifications

Must meet all the specifications in tables 8B–3 and 8B–4.

Table 8B–3 Receiver specifications

Characteristic	Specification
Frequency	37–50 MHz .0005% Synthesized 10KHz steps
Modulation	Type—BPSK Rate—4 kbps Format—NRZ
Noise figure	< 7 dB minimum
Sensitivity: Bit Error Rate < 10 ⁻³ at 4 kbps	–120 dBm
IF Bandwidth (3/80 dB)	13/40 KHz typical
RF Bandwidth (3 dB)	13 MHz typical
Signal acquisition time	< 5 msec
3rd order intercept point	>– 4 dBm
Image response attenuation	> 70 dB minimum
Spurious response attenuation	> 70 dB minimum
SP Threshold	Adjustable from –115 to –106 dBm Triggered by DET RF and demodulator lock
Noise blanker	> 20 dB reduction in impulse noise
I/O	Meteor burst standard

Criteria***Installation***

The radio must be securely mounted inside the NEMA enclosure. The radio should be positioned so that all the connections are easily accessible to connect wires, power, and communication cables.

Maintenance and calibration

Shop procedures should be done to all radios as needed. Maintenance and calibration should be performed by the NRCS Electronics Maintenance Facility (EMF). Radios that have been removed from the field should be shipped to EMF for inspection and repair.

Field procedures must be done during routine site maintenance visits to SNOTEL stations, usually scheduled on an annual basis, or during unscheduled site visits when station performance is suspect.

Shop and field calibration must be done following methods and specifications described in NEH622.05.

Shop maintenance and calibration

Shop maintenance and calibration procedures should be performed as needed, unless the radio fails in the field.

Field maintenance and calibration

Field maintenance and calibration procedures must be performed at each scheduled site maintenance visit, or once a year.

Table 8B-4 Transmitter specifications

Characteristic	Specification
Frequency	37–50 MHz .0005% Synthesized 10KHz steps
RF power output	> 100 watts at 12 VDC input
Load VSWR	< 2:1 rated power
Harmonic levels	70 dB below unmodulated carrier
Modulation	Type—BPSK Rate—4 kbps Format—diff
Spurious	> 70 dB below unmodulated Carrier
Transmit Modulation Spectrum	10 KHz offset—40 dB 25 KHz offset—70 dB
Tx duty cycle	16% max without shutting down transmitter 20% will shut down the transmitter
T/R switch	Solid-state Switching time < 100 microseconds
I/O	Meteor burst standard
High VSWR protection	Withstands infinite VSWR

Replacement

Radios should be replaced every 6 years maximum. The batteries in the meteor burst radio should be replaced every 3 years.

Considerations

Environmental conditions at remote sites are highly variable and uncontrollable. Extreme cold, heat, wind, rain, snow, and ice may cause unexpected reactions from the radio. Unusually harsh conditions may require maintenance and calibration verification be performed more often than specified to ensure data quality.

Inconsistencies in electronic components and mounting configurations can affect the performance of radios. Every effort should be taken to recognize any inconsistency that might account for performance problems, and then eliminate the inconsistency when possible.

Radios that cannot be repaired must be permanently removed from supply stock and be disposed of appropriately.

Responsibilities

The NRCS DCO is responsible for maintaining and ensuring calibration of all radios used at SNOTEL station installations in its associated region.

References

National Communications System. 1992. Evaluation of advanced meteor burst communication techniques. Technical Information Bulletin 92-20.

U.S. Department of Agriculture, Natural Resources Conservation Service. 2011. National Engineering Handbook, Part 622, Snow Survey and Water Supply Forecasting Handbook. Washington, DC.

SNOTEL Shelter

Definition

The shelter is a building designed to house snow telemetry (SNOTEL) station electronics and manometers.

Purpose

The purpose of this standard is to provide the requirements for installation and maintenance of the SNOTEL shelter in order to ensure the structure is adequately constructed and maintained to prevent damage to or malfunction of equipment housed within the shelter.

Conditions where this standard applies

This standard applies to all shelters on SNOTEL sites installed, operated, or maintained by NRCS.

Criteria

Installation

- All shelters should be constructed consistent with the appropriate standard drawings in NEH622.08 appendix G.
- Shelters must:
 - be structurally sound
 - be designed to withstand maximum anticipated snow and wind loads (with minimum maintenance)
 - exceed a 25-year service life
- Door jams and floor joints must be sealed adequately to prevent the entry of all rain and blowing snow, rodents, etc.
- Typical building size is 4-feet wide by 4-feet long by 8 feet (minimum) and up to 30 feet in height.
- Shelter walls must be vertical; shelter floors must be horizontal.
- The shelter roof must be securely attached to the shelter walls.
- All exposed fasteners must be noncorrosive. All hinges, barrel bolts, or hasps must be heavy duty and must be attached in such a way as to prevent removal from outside the shelter.
- All plywood must be three-eighths-inch exterior grade or better.
- The lower door must be a split, Dutch-style door. Shelters 12 feet or taller must also have an upper door.
- At least one screened vent is required, and two vents is often desirable. One vent should be near the top. If two vents are used one should be near the floor and the other vent near the top, installed on opposite walls.
- Exterior and interior ladders on shelters higher than 8 feet will provide access during high snowpack conditions.
- At a minimum, the lower 4 feet of the outside shelter exterior must have a protective covering to guard against animal and rodent damage. Typically, this consists of either hardware cloth or metal siding.
- Shelters should not be installed on slopes over 25 percent, except in rare circumstances, and should not interfere with the proper operation of any of the sensors at the site.

- Shelters should be located as close as practical to the snow pillow and precipitation gage, with sufficient downslope to attain a minimum manometer reading between 10 to 20 inches above the floor.
- The shelter must be anchored to secure footings such as concrete, pier blocks, or railroad ties, designed to a minimum 25-year life expectancy. The foundation must be of sufficient strength to keep the structure plumb and minimize settling or heaving.
- When using a railroad tie foundation, a two-tie foundation is recommended for an 8-foot shelter. A four-tie foundation is recommended for a 12- or 16-foot shelter. When using a four-tie foundation, perpendicular ties must be connected using a steel plate.
- When using concrete pier footings, concrete piers must be a minimum of 12 inches diameter with minimum a depth of 24 inches for an 8-foot shelter; 30 inches for a 12-foot shelter; or 36 inches for a 16-foot shelter.
- If shallow depths to rock preclude adequate depths for the footers, then a wider footprint or anchoring via rebar or expansion bolts into the rock may be used to secure the shelter.
- Shelters must contain a NEMA enclosure or similar enclosure to provide additional protection to radio and data logging equipment.
- All conduit and plumbing entrances must be sealed using a silicone sealant or duct seal.

Considerations

- Shelters may be completely constructed in advance, as outlined in NEH622.04, or built as wall panels and assembled at the site. Prebuilt shelters have been found to be very durable. They are also weather-resistant, animal-resistant, and insect-resistant. High quality, prebuilt shelters can be constructed at a reasonable cost. However, transporting and placing prebuilt shelters can be challenging at some SNOTEL site locations. Wall panels may be more easily transported to difficult sites.
- At sites requiring an antenna tower and a meteorological tower, it is recommended to have the transmit antenna tower attached to the shelter to provide additional strength to both the tower and the shelter.
- Plumbing entering the shelter should come in through the floor, directly under the manometer valves where possible. When it is not possible to bring plumbing through the floor, side entry is acceptable, but such installations are more prone to damage.
- Transducers should be mounted in such a fashion as to maintain a stable reading, but still permit review of the “data plate” and provide easy removal when necessary.
- Batteries should be directly below the NEMA enclosure, and all sensor and power wires should be long enough to allow minor adjustments, but not excessively long to avoid safety and data quality problems.
- Customized shelter designs may be required to accommodate specific site features. For example, structures located in the vicinity of other buildings or structures may need to be designed to blend in with the other existing structures.
- Each shelter must have a SNOTEL data site sign permanently posted on the front of the building at eye level or a height above the deepest expected snow depth. The SNOTEL sign must be highly visible on the building (See SNOTEL Data Site sign standard drawing in appendix 8G.)

Plans and specifications

Plans and specifications for all shelters used at SNOTEL stations must be in keeping with this standard. Drawings for a typical SNOTEL shelter are in appendix 8G of this standard. Plans and specifications must be prepared for shelter installations at specific sites and maintained as part of the site records and documentation. A site sketch must show the shelter location.

Operation and maintenance

Regular inspection of the shelter must be part of an ongoing maintenance program at each site. Maintenance and repairs will be performed in a timely manner as needed. All broken and replaced material and hardware must be removed and properly discarded. All necessary precautions should be taken to ensure the safety of construction and maintenance crews.

References

National Electrical Manufacturers Association. 2008. Type 3, Enclosures for electrical equipment (1000 volts maximum) Standards Publication 250–2008. Rosslyn, VA.

U.S. Department of Agriculture, Natural Resources Conservation Service. 2011. National Engineering Handbook, Part 622, Snow Survey and Water Supply Forecasting Handbook. Washington, DC.

SNOTEL Solar Panel

Definition

Photovoltaic cell solar panels are used to power SNOTEL stations indirectly through a battery bank. The proper size and number of solar panels ensure the remote station will operate without breakdown due to lack of power.

Purpose

The purpose of this standard is to provide field maintenance and calibration criteria for solar panels to:

- ensure reliable operation of solar panels and proper charging of the SNOTEL battery power system in order to reliably transmit data from SNOTEL stations
- minimize the number of unexpected site visits due to radio or data logger failure due to power loss attributable to solar panel failure

Conditions where this standard applies

This standard applies to all solar panels installed on SNOTEL data collection stations installed, operated, or maintained by NRCS.

Criteria

Installation

- Panels must be installed well above the highest level that the snow depth would expect to reach.
- Panels must be securely attached to the antenna tower at least 3 feet from the antenna and all other sensors. Some panels may need to be mounted high in trees to rise above the canopy.
- The angle of the sensor should be set approximately equal to the station's location in latitude degrees, or adjusted to maximize solar exposure during winter months. The panel may need to be oriented nearly vertical to prevent snow accumulation in some locations.
- The solar panel should be oriented to the south or in the proper direction to ensure the best solar window available for maximum solar exposure at the given location.
- Proper installation of solar panels includes the use of regulators to regulate the amount of voltage reaching the batteries to protect them and the electronic components from being damaged during the brightest times of the day.

Field calibration and maintenance

- The solar panels must be inspected during each visit to the SNOTEL station, or at least once during the year to ensure they are working properly.
- The panels must be cleaned at least once a year or as needed.
- The angle and orientation of the panes must be checked and adjusted if necessary.
- Make sure the panels are secured tightly to whatever they are mounted on.

Considerations

The more batteries used to power the station, the more solar panels or the larger the solar panels required to keep the battery power system charged. Although solar panels are available in extremely large sizes and power outputs, the physical size is a concern at SNOTEL installations for practical reasons of managing the panels with limited equipment. Also, solar panels can act as sails and create undesirable wind loads on the tower.

The number and size of the solar panels to keep the station operating also depends on the setting of the station. Stations in higher latitudes require more solar panels in order to make up for a lack of daylight hours in the winter months. Also, stations in extremely wet and cloudy regions may require more panels. Often, the radio and data logger are powered off of separate batteries. Typically, a 50-watt panel is sufficient to operate the radio with two batteries, while a 10-watt panel will operate the logger with one battery.

Plans and specifications

Plans and specifications associated with solar panels considered for use at SNOTEL stations must be in keeping with this standard.

Responsibilities

The NRCS DCO is responsible for maintaining and ensuring calibration of all SNOTEL solar panels in its associated region.

References

U.S. Department of Agriculture, Natural Resources Conservation Service. 2011. National Engineering Handbook, Part 622, Snow Survey and Water Supply Forecasting Handbook. Washington, DC.

SNOTEL Tower

Definition

The SNOTEL tower is a fabricated metal stand onto which a transmit/receive antenna, solar panels, meteorological sensors, or some combination of these are mounted.

Purpose

The purpose of this standard is to provide specifications and installation criteria for SNOTEL towers to ensure data quality and consistency of data collected at SNOTEL stations installed, operated, or maintained by NRCS.

Conditions where this standard applies

This standard applies to towers up to 30 feet in height used for mounting transmit/receive antennae, solar panels, and meteorological sensors for automated remote SNOTEL data collection stations installed by NRCS.

Criteria

Antenna tower installation

- The minimum height of an antenna tower is 20 feet, not including the antenna mast.
- A mast must be used at the top of the antenna tower to mount solar panels and transmit/receive antennae.
- The mast must be constructed from a minimum diameter of one and one-quarter-inch galvanized pipe or schedule-40 heavy-duty aluminum conduit.
- The mast must be a minimum of 5 feet in length and may be a maximum of 10 feet in length.
- Lightning arresters may be mounted at the top of the mast.

Meteorological tower installation

- For SNOTEL station installations which include a snow pillow, the meteorological tower must be placed such that the snow depth sensor is mounted directly over the snow pillow.
- The meteorological tower should be placed such that the sensors have a minimum of 30-degree clear view of the sky as measured from vertical.
- The minimum height of the meteorological tower must be determined based on minimum distance from maximum snow depth for the meteorological sensors mounted on the tower.

Considerations

Mounting of sensors and components is sensor-specific and is addressed in individual installation standards.

Solar panels must be mounted on the vertical mast or where appropriate to maximize winter sun and minimize shadows on the sensors.

Plans and Specifications

- Plans and specifications for all SNOTEL towers must be in keeping with this standard.
- All towers must be Rohn 25 G or equivalent or larger, capable of an OSHA 5,000-pound dead weight test.

Operation and Maintenance

Towers must be inspected annually during routine site maintenance visits to remote SNOTEL station or during any unscheduled site visits.

Warning: Prior to climbing a tower to service sensors or electronics, the tower must be inspected for any signs of structural damage such as cracking, bending, or other deformation. Towers must also be checked for plumb. If problems are found, the structure must be replaced.

References

U.S. Department of Agriculture, Natural Resources Conservation Service. 2011. National Engineering Handbook, Part 622, Snow Survey and Water Supply Forecasting Handbook. Washington, DC.

Rohn™. 2011. 25G Guyed Tower Series Specifications.

The sensors standards and specifications must be compatible with the current data logger and transmission system in the collection of data at remote SNOTEL sites.

This appendix contains the following standards and specifications:

- Air Temperature Sensor
- Barometric Pressure Sensor
- Pressure Transducer
- Relative Humidity Sensor
- Snow Depth Sensor
- Snow Pillow Snow Water Equivalent (SWE) Sensor
- Soil Moisture and Soil Temperature Sensor
- Solar Radiation Sensor
- Storage Precipitation Gage
- Tipping Bucket Precipitation Gage
- Wind Speed and Wind Direction Sensor

Air Temperature Sensor

Definition

A sensor used to measure air temperature (thermometer). Air temperature refers to the ambient temperature at a given height above the ground.

Purpose

The purpose of this standard is to:

- ensure data quality and consistency of air temperature data collected by NRCS
- minimize the number of unexpected site visits due to sensor failure

Conditions where this standard applies

This standard applies to air temperature sensors and air temperature data collected using automated remote snow telemetry (SNOTEL) data collection stations installed, operated, or maintained by NRCS.

Criteria

Installation

- The air temperature sensor must be mounted on the meteorological tower and housed inside a naturally aspirated, 5- or 10-vane gill solar radiation shield, white in color.
- The sensor must be mounted on the meteorological tower using 1-inch galvanized pipe, or an equally sturdy attachment, in a horizontal configuration so that the air temperature sensor is placed a minimum of 2 feet away from the tower leg.
- The air temperature sensor must be mounted away from any potential heat-producing area, such as a snow pillow.
- Mounting height for this sensor varies depending on the amount of anticipated maximum snow depth, if any. Refer to table 8C–1 for mounting heights.
- The height of the air temperature sensor must be recorded in the metadata.

Calibration and maintenance

- Data from field sensors must be used to determine the need for sensor calibration and/or maintenance.
- A full calibration check may be performed in the field or in the shop. All sensors must be calibrated before being installed in the field.

Table 8C–1 Air temperature sensor mounting height

Anticipated maximum snow depth	Mounting height of air temperature sensor
Little or no snow	7 feet above ground level ± 1 foot
10 feet	18 feet above ground level ± 1 foot
20 feet	28 feet above ground level ± 1 foot

- All sensors installed in the field must be inspected annually for physical damage, secure mounting, proper wiring, and to ensure freedom from debris or erosion.
- An annual, single-point field calibration check must be made during routine site maintenance visits to remote SNOTEL data collection stations and during any unscheduled site visits, usually made when data appears suspect. Site maintenance visits are usually scheduled on an annual basis.
- Sensors currently in the field must be replaced with a shop-calibrated sensor or have a full field calibration check at least every 6 years. When replacing the air temperature sensor all installation standards and data verification procedures must be performed. See NEH622.05, Maintenance and Calibration.
- Sensors that pass the full performance test in the Electronics Maintenance Facility (EMF) are to be labeled as calibrated and include the date of calibration and initials of the technician.
- Sensors that do not pass or cannot be repaired must be permanently removed from supply stock and be disposed of appropriately.

Calibration and maintenance procedures

- Calibration must be made following the methods and procedures described in NEH622.05. A calibration check is made by comparing field sensor readings to ambient air temperature readings obtained using a mercury column thermometer, a calibrated hand-held electronic thermometer, or a calibrated sensor identical to the sensor being checked.
- A field check is made by taking a reference ambient air temperature measurement in the shade as near to the field sensor as reasonably possible.
- A single-point verification of ambient air temperature is required annually.
- A full calibration check of the air temperature sensor, whether in the field or in the shop consists of taking a minimum of three temperature readings ranging at least 15 degrees Celsius between each point. Each temperature reading must be within ± 3 degrees Celsius of the reference thermometer or sensor and traceable to NIST. This three-point check must be performed every 6 years.

Recordkeeping

Records for maintenance or calibration done at EMF will be recorded by the NRCS EMF staff. Maintenance and calibration records must be maintained for the life of each SNOTEL data collection site. Records must be kept of all field and shop procedures and include the maintenance and calibration of each sensor by its serial number. Records must be maintained on official data site forms or site ledgers and entered into the central database.

Data parameters

See NEH622.02, Data Parameters, for data parameters associated with air temperature measurements.

Considerations

Environmental conditions at remote sites are highly variable and uncontrollable. Extreme cold, heat, wind, rain, snow, and ice may cause unexpected reactions from the sensor. Unusually harsh conditions may require maintenance and calibration verification be performed more often than specified to ensure data quality.

Inconsistencies in electronic components and mounting configuration can affect the performance of a sensor. Every effort should be taken to recognize any inconsistency that might account for performance problems and then eliminate the inconsistency when possible.

Plans and specifications

Plans and specifications for air temperature sensors and sensor installation must be in keeping with this standard. Maintenance plans must be developed for each SNOTEL data collection station. These plans must be reviewed periodically and adjustments or modifications made as needed.

Operation and maintenance

Data from air temperature sensors should be evaluated on a weekly basis to determine sensor calibration performance. See NEH622.06, Data Management, for further details on data collection and performance standards.

Sensors that cannot be repaired must be permanently removed from supply stock and be disposed of appropriately.

Responsibilities

The NRCS data collection office (DCO) is responsible for proper data collection at all SNOTEL stations and snow courses in its associated region. The DCO is also responsible for maintaining and ensuring calibration of sensors at all SNOTEL stations.

The NRCS National Water and Climate Center (NWCC) is responsible for developing data collection standards and sensor maintenance and calibration standards. All standards must be periodically reviewed and adjusted or modified as needed.

References

U.S. Department of Agriculture, Natural Resources Conservation Service. 2011. National Engineering Handbook, Part 622, Snow Survey and Water Supply Forecasting Handbook. Washington, DC.

Vaisala. 2004. HMP45C-L Operating Manual, Campbell Scientific, Logan Utah.

YSI Precision. Series 44000 Thermistor Specifications. Therm-X. Hayward, CA.

Barometric Pressure Sensor

Definition

A sensor designed to measure barometric pressure. Barometric pressure is defined as the pressure exerted by the weight of a column of air (dry air and water vapor mixture) above a given point.

Purpose

The purpose of this standard is to:

- ensure data quality and consistency of barometric pressure data collected by NRCS
- minimize the number of unexpected site visits due to sensor failure

Conditions where this standard applies

This standard applies to barometric pressure sensors and barometric pressure data collected using automated remote snow telemetry (SNOTEL) data collection stations installed, operated, and maintained by NRCS.

Criteria

Installation

Barometric pressure sensors must be mounted inside the NEMA enclosure and must be well-vented to outside the enclosure.

Calibration and maintenance

Calibration must be performed following the methods and procedures described in NEH622.05.

Shop calibration and maintenance

- Barometric pressure sensors are extremely sensitive and go out of calibration easily. It is extremely difficult to test the calibration for the entire range of the sensor in the field. Complete calibration checks and repair must be done at NRCS EMF every 3 years.
- Used sensors must be evaluated for their remaining life expectancy. Sensors with a life expectancy of less than 3 years must be sent to the manufacturer for refurbishing or discarded appropriately.
- Barometric pressure sensor operating performance must be within ± 3 percent (about 0.03 in Hg) of the calibration reference barometer for the entire range of measurement.
- Barometric pressure sensors that pass the performance test should be labeled as calibrated with the date of calibration and technician initials.
- The sensor casing and components must be inspected for physical damage or wear.
- The sensor must be cleaned and damaged parts repaired.
- All maintenance and calibration procedures must be documented and associated with the serial number of each sensor.

Field calibration and maintenance

- Field calibration checks must be performed during each annual site maintenance visit to the SNOTEL station. See NEH622.05.
- The sensor at the SNOTEL station must be replaced with a currently calibrated sensor every 3 years.
- The vent tube must be inspected for clear venting to the atmosphere.
- Calibrated, hand-held barometers must be used to check the calibration of the sensor.

- Calibration checks may be done by comparing station data to local, certified NWS NOAA data.
- All calibrated reference barometers used to check sensor calibration must be calibrated at least once a year. Calibration may be done using a mercury column barometer, NWS station, or the manufacturer's specifications. Calibration adjustments should only be done at the NRCS EMF shop or at the manufacturer.
- The sensor must be replaced if there is over ± 3 percent (about 0.03 in Hg) difference from the calibrated unit. When replacing any sensor all installation standards and data verification procedures must be performed.

Recordkeeping

Records for maintenance or calibration done at EMF must be recorded by the NWCC EMF staff. Maintenance and calibration records must be maintained for the life of each SNOTEL data collection site. Records must be kept of all the field and shop procedures and include the maintenance and calibration of each sensor by its serial number. Records must be maintained on official data site forms or ledgers and entered into the central database.

Data parameters

See NEH622.02 for data parameters associated with barometric pressure measurements.

Considerations

Environmental conditions at remote sites are highly variable and uncontrollable. Extreme cold, heat, wind, rain, snow, and ice may cause unexpected reactions from the sensor. Unusually harsh conditions may require maintenance and calibration verification be performed more often than specified to ensure data quality.

Inconsistencies in electronic components and mounting configurations can affect sensor performance. Every effort should be taken to recognize any inconsistency that might account for performance problems, and then eliminate the inconsistency when possible.

Plans and specifications

Plans and specifications associated with all barometric pressure sensors considered for use at SNOTEL stations must be in keeping with this standard. Maintenance plans must be developed for each SNOTEL data collection station. These plans must be reviewed periodically and adjustments or modifications made as needed.

Operation and maintenance

Data from barometric pressure sensors should be evaluated on a weekly basis to determine sensor calibration performance. See NEH622.06 for further details on data collection and performance standards.

Sensors that cannot be repaired must be permanently removed from supply stock and be disposed of appropriately.

Responsibilities

The NRCS DCO is responsible for proper data collection at all SNOTEL stations and snow courses in its associated region. The DCO is also responsible for maintaining and verifying calibration of sensors at all SNOTEL stations.

The NRCS National Water and Climate Center is responsible for developing data collection standards and sensor maintenance and calibration standards. All standards must be periodically reviewed and adjusted or modified as necessary.

References

U.S. Department of Agriculture, Natural Resources Conservation Service. 2011. National Engineering Handbook, Part 622, Snow Survey and Water Supply Forecasting Handbook. Washington, DC.

Vaisala Corporation. 2011. PTB110 Barometer Operating Manual, Campbell Scientific. Logan UT.

Pressure Transducer

Definition

Pressure transducers are electronic devices used to measure hydrostatic head. Pressure transducers are used in fluid snow pillows and storage precipitation gages at SNOTEL installations to measure snow water equivalency (SWE) and total precipitation.

Purpose

The purpose of this standard is to provide installation, calibration, and maintenance criteria to:

- ensure data quality and consistency of SWE and precipitation data collected by NRCS
- minimize the number of unexpected site visits due to sensor failure

Conditions where this standard applies

This standard applies to pressure transducers at remote snow telemetry (SNOTEL) data collection stations installed, operated, or maintained by NRCS.

Criteria

Installation

- Transducers must be rated for measurements at least 50 percent above the maximum expected measurement.
- Transducers must be secured firmly to the SNOTEL shelter.
- The pressure transducer should be located as close to the bottom of the manometer as possible.
- The height of the manometer must be measured from the floor of the SNOTEL shelter.
- All air must be purged from the transducer through the bleed port and through the plumbing connection.
- Transducers should be oriented so the plumbing is pointed up to prevent air bubbles from accumulating inside the transducer.
- Calibration verification must be performed on all newly installed transducers.
- Manometer tubing must be attached to the transducer securely.
- Transducer tubing should be clear or translucent enough to see clearly the level of the fluid in the tube and to see any air bubbles in the line. There should not be loops that could trap air.

Calibration and maintenance

Shop calibration and maintenance

- All pressure transducers must be returned to the NWCC Electronics Maintenance Facility (EMF) for testing and recalibration every 6 years.
- Transducer shop calibration must be performed following methods and specifications described in NEH622.05.
- Transducers must be evaluated and calibrated using primary standards for pressure and temperature as well as calibrated power supplies, multimeters, and data acquisition systems. The pressure source must be extra dry nitrogen.
- Upon receipt of new or used pressure transducers, they must be checked for signal output at zero pressure and 100 percent pressure to ensure operability. This must be done at room temperature (23.9 °C). These values must be recorded for each transducer before initial calibration.
- New transducers must go into the test/aging process as they are.

- Used transducers must be evaluated for the remaining life expectancy. Transducers with an expected life expectancy less than 6 years must be sent to the manufacturer for refurbishing or discarded appropriately.
- Used transducers will have their “zero” and “full-scale” values recorded and will then be adjusted within calibration specs.
- All transducers must be checked for performance at 25 degrees Celsius and –20 degrees Celsius. At each temperature range, they must be tested for voltage output at zero and full-range pressure. These pressures must be stepped up at 10 percent full pressure steps, and the output values recorded for each transducer at each pressure step on their individual calibration forms. The pressure readings at –20 degrees Celsius must not be more than ± 65 mV different from the same pressure readings at 25 degrees Celsius. No transducer reading at the rated pressure or temperature may be ± 10 mV from factory specification.
- The transducer must be pressure-cycled (aged) 1,000 times between zero pressure and full range pressure. The transducer must also be temperature-cycled (aged) 100 times between +40 and –40 degrees Celsius. Performance checks must be done after pressure and temperature aging.
- Used transducers with no more than a 10 mV drift between the initial values and the aged values will be allowed.
- New transducers with no more than a 25 mV drift between the initial values and the aged values will be allowed.
- Transducers that pass the performance tests must be labeled as calibrated with the date of calibration and technician initials.
- All maintenance and calibration procedures must be documented and associated with the serial number of each sensor.

Field calibration and maintenance

- Transducers in the field must be replaced every 6 years with a calibrated and tested transducer from EMF. Removed transducers should be sent to manufacturer for refurbishing or discarded appropriately.
- When replacing any sensor all installation standards and data verification procedures must be performed. See NEH622.04 for further details.
- Field maintenance and calibration verification must be done at each scheduled site maintenance visit, or at least once a year. Transducer field checks must be done following methods described in NEH622.05.
- The transducer output must be compared to the calculated head reading, using the data logger output or a calibrated voltmeter.
- The transducer must be within ± 2 percent scale range of correct reading. Transducers that do not fall within this specification must be replaced with a currently calibrated sensor.

Recordkeeping

Records for maintenance or calibration completed in the EMF shop will be recorded by the NWCC EMF staff. Maintenance and calibration records must be maintained for the life of each SNOTEL data collection site. Records must be kept of all the field and shop procedures and include the maintenance and calibration of each sensor by its serial number. Records must be maintained on official data site forms or ledgers and entered into the central database.

Considerations

Environmental conditions at remote sites are highly variable and uncontrollable. Extreme cold, heat, wind, rain, snow, and ice may cause unexpected reactions from the sensor. Unusually harsh conditions may require maintenance and calibration verification be performed more often than specified to ensure data quality.

Inconsistencies in electronic components and mounting configurations can affect the performance of sensors. Every effort should be taken to recognize any inconsistency that might account for performance problems, and then eliminate the inconsistency when possible.

Plans and specifications

Plans and specifications for maintenance and calibration of transducers must be in keeping with this standard.

Operation and maintenance

Maintenance plans must be developed. Plans must be periodically reviewed and adjustments or modifications must be made as needed.

Data from transducer pressure sensors should be evaluated on a weekly basis to determine sensor calibration performance. See NEH622.06 for further details on data collection and performance standards.

Sensors that cannot be repaired must be permanently removed from supply stock and be disposed of appropriately.

Responsibilities

The NRCS DCO is responsible for proper data collection at all SNOTEL stations and snow courses in its associated region. The DCO is also responsible for maintaining and ensuring calibration of all sensors at all SNOTEL stations.

The NWCC is responsible for developing data collection standards and sensor maintenance and calibration standards. All standards must be periodically reviewed, and adjusted or modified as necessary.

References

U.S. Department of Agriculture, Natural Resources Conservation Service. 2011. National Engineering Handbook, Part 622, Snow Survey and Water Supply Forecasting Handbook. Washington, DC.

Relative Humidity Sensor

Definition

A sensor used to measure relative humidity. Relative humidity is defined as the ratio of water vapor in the air at a specific temperature to the maximum capacity of the air at that temperature.

Purpose

The purpose of this standard is to:

- ensure data quality and consistency of relative humidity data collected by NRCS
- minimize the number of unexpected site visits due to sensor failure

Conditions where this standard applies

This standard applies to relative humidity sensors and relative humidity data collected using automated remote snow telemetry (SNOTEL) data collection stations installed, operated, or maintained by NRCS.

Criteria

Installation

- The sensor must be mounted to the meteorological tower, and is typically associated with the air temperature sensor.
- The sensor must be mounted to the meteorological tower using 1-inch galvanized pipe in a horizontal configuration.
- The relative humidity sensor must be placed a minimum 2 feet away from the tower leg.
- If a snow pillow is installed, the air temperature sensor must be mounted facing away from the pillow or other possible heat-producing areas.
- Mounting height for this sensor will vary depending on the amount of anticipated maximum snow depth, if any. Refer to table 8C–2 for sensor mounting heights.
- The sensor must be inserted into a normally aspirated, 10-vane Gill shield, white in color.
- The height of the relative humidity sensor must be recorded in the metadata.

Calibration and maintenance

Shop calibration and maintenance

- Shop calibration checks must be performed annually, unless the sensor fails in the field.
- Shop calibration must be performed following methods and specifications described in NEH622.05, Calibration and Maintenance.

Table 8C–2 Mounting height of relative humidity sensor based on maximum snow depth

Anticipated maximum snow depth	Mounting height of relative humidity sensor
Little or no snow	7 feet above ground level \pm 1 foot
10 feet	18 feet above ground level \pm 1 foot
20 feet	28 feet above ground level \pm 1 foot

- Used sensors must be evaluated for their remaining life expectancy. Sensors with a life expectancy of less than 2 years must be discarded appropriately.
- The relative humidity sensors must be evaluated and calibrated using manufacturer-designed techniques and primary standards for humidity and temperature, as well as calibrated power supplies, multimeters, and data acquisition systems.
- The humidity source for calibration must be either primary salt solutions or a chilled mirror calibration chamber traceable to NIST.
- The temperature reading must be verified against a calibrated mercury thermometer traceable to NIST. The output of the sensors must be connected to a calibrated data logger to collect the readings for evaluation.
- The sensor outputs must be adjusted to within ± 1 degree of the thermometer and to humidity ± 1 percent of the expected relative humidity reading.
- This process must be repeated until both readings are within ± 1 percent of the salt solutions.
- Sensors that pass the performance test should be labeled as calibrated with the date of calibration and technicians initials.
- Sensors that do not pass the performance test must be immediately replaced.
- All maintenance and calibration procedures must be documented and associated with the serial number of each sensor.

Field calibration and maintenance

Relative humidity sensors must be replaced annually.

Recordkeeping

Records for maintenance or calibration done in the EMF shop will be recorded by the NWCC EMF staff. Maintenance and calibration records must be maintained for the life of each SNOTEL data collection site. Records must be kept of all the field and shop procedures and include the maintenance and calibration of each sensor by its serial number. Records must be maintained on official data site forms or ledgers and entered into the central database.

Data parameters

See NEH622.02 for data parameters associated with relative humidity measurements.

Considerations

Several styles of relative humidity sensors are currently used in SNOTEL stations. Different algorithms are used to convert the raw voltage values to engineering values. The specific algorithm must be used to provide accurate readings. Various manufactures are acceptable, for example, Vaisala HMP45 or Vaisala HMP35. The listing of these sensors by the government does not endorse their use. They are identified here solely as examples of what are currently being used in these networks.

Plans and specifications

Plans and specifications associated with all relative humidity and air temperature sensors considered for use at SNOTEL stations must be in keeping with this standard. Maintenance plans must be developed for each SNOTEL data collection station. These plans must be reviewed periodically and adjustments or modifications made as needed.

Operation and maintenance

Data from relative humidity and air temperature sensors should be evaluated on a weekly basis to determine sensor calibration performance.

Sensors that cannot be repaired must be permanently removed from supply stock and be disposed of appropriately.

Responsibilities

The NRCS DCO is responsible for proper data collection at all SNOTEL stations and snow courses in its associated region. The DCO is also responsible for maintaining and verifying calibration of sensors at all SNOTEL stations.

The NRCS NWCC is responsible for developing data collection standards and sensor maintenance and calibration standards. All standards must be periodically reviewed and adjusted or modified as necessary.

References

U.S. Department of Agriculture, Natural Resources Conservation Service. 2011. National Engineering Handbook, Part 622, Snow Survey and Water Supply Forecasting Handbook. Washington, DC.

Vaisala. 2004. HMP45C-L Operating Manual, Campbell Scientific, Logan Utah.

Snow Depth Sensor

Definition

Snow depth refers to the depth of the snow above the ground. A snow depth sensor is used to measure snow depth.

Purpose

The purpose of this standard is to:

- ensure data quality and consistency of snow depth data collected by NRCS
- minimize the number of unexpected site visits due to sensor failure

Conditions where this standard applies

This standard applies to snow depth sensors and snow depth data collected using automated remote snow telemetry (SNOTEL) data collection stations installed, operated, or maintained by NRCS.

Criteria

Installation

- This sensor must be mounted directly above the snow pillow and attached to the meteorological tower.
- The mounting height must be a minimum of 4 feet above the maximum anticipated snow depth. The higher the snow depth sensor is mounted, the farther the sensor must be away from the antenna tower so as not to interfere with the measurements. It is recommended that the sensor be moved away from the tower 2 feet for every 10 feet of height.
- The snow depth sensor must be a minimum of 3 feet from the tower leg and a maximum of 6 feet to help reduce bouncing of the sensor in windy conditions.
- All brush or other obstacles must be removed from the area that the sensor will see in order to obtain accurate measurements.
- The height of the snow depth sensor must be recorded in the metadata so a proper offset can be entered and the sensor can be checked for accuracy.

Calibration and maintenance

Shop calibration and maintenance

- Shop calibration checks must be performed at least once every 6 years.
- Shop calibration must be done following methods and specifications described in NEH622.05.
- Used sensors must be evaluated for their remaining life expectancy. Sensors with a life expectancy less than 3 years must be sent to the manufacturer for refurbishing or discarded appropriately.
- Sensor casing and components must be inspected for physical damage or wear.
- Sensors must be cleaned and damaged parts repaired.
- All sensor electrical properties must be bench tested for performance that is within specifications.
- All depth sensors operation performance must be evaluated at 3-foot intervals to a distance of 30 feet.
- All measurement verification must be done using a flat surface perpendicular to the sensor.
- Sensor measurements must be within 1 inch of the actual distance. If adjustments can be made to the sensor to calibrate the measurements, then they should be done to bring the performance within the 1-inch requirement for each reading from 3 to 30 feet. If the sensor cannot be adjusted within the 1-inch requirement, then it must be repaired or replaced.

- Depth sensors that pass the performance test should be labeled as calibrated with the date of calibration and technician initials.
- All maintenance and calibration procedures should be documented and associated with the serial number of each sensor.

Field calibration and maintenance

- Field maintenance and calibration verification must be performed at each scheduled site maintenance visit or once a year.
- Field calibration verification should be done following methods and specifications described in NEH622.05.
- Inspection of the depth sensor and associated mounting hardware should be conducted.
- Proper alignment should be checked to ensure the sensor is in the vertical position.
- A one-point calibration check should be performed at least once a year.
- Every 6 years, a three-point calibration check must be performed, or the sensor should be replaced with one that is currently calibrated. Repairs may be performed by the DCO. Repairs that cannot be performed by the DCO should be performed by the NRCS Electronics Maintenance Facility (EMF) staff. Sensors repaired by the EMF shop will have full calibration checks. Full calibration checks should be performed on all sensors before being returned to the field. When replacing any sensor, all installation standards and data verification procedures must be performed. See NEH622.04.
- Minimum annual calibration verification may be done using the existing distance to ground or snow surface or using a flat object on these surfaces. The sensor must be replaced if there is over ± 3 inches variance of the actual measurement.
- A 6-year calibration check in the field must consist of three sample measurements taken at distances of about 20, 40, and 60 percent of the height above ground of the sensor. The sensor must be replaced if there is over ± 3 inches variance of the actual measurement. Calibration checks should be done using a smooth flat surface that is perpendicular to sensor.
- Depth sensors that fail the calibration verification and cannot be repaired by the DCO should be sent to the EMF shop for repair.
- Annual vegetation management in the immediate vicinity of the snow pillow should be adequate. However, at sites with deeper snowpacks the target area will be larger, and vegetation management should encompass the entire target area.

Recordkeeping

Records for maintenance or calibration done in the EMF shop will be recorded by the EMF staff. Maintenance and calibration records must be maintained for the life of each SNOTEL data collection site. Records must be kept of all the field and shop procedures and include the maintenance and calibration of each sensor by its serial number. Records must be maintained on official data site forms or ledgers and entered into the central database.

Data parameters

See NEH622.02 for data parameters associated with snow depth measurements.

Considerations

Environmental conditions at remote sites are highly variable and uncontrollable. Extreme cold, heat, wind, rain, snow, and ice may cause unexpected reactions from the sensor. Unusually harsh conditions may require maintenance and calibration verification be performed more often than specified to ensure data quality.

Inconsistencies in electronic components and mounting configuration can affect the sensor performance. Every effort should be taken to recognize any inconsistency that might account for performance problems, and then eliminate the inconsistency when possible.

Plans and specifications

Plans and specifications associated with all sonic snow depth sensors considered for use at SNOTEL stations must be in keeping with this standard. Maintenance plans must be developed for each SNOTEL data collection station. These plans must be reviewed periodically and adjusted or modified as necessary.

Operation and maintenance

Data from snow depth sensors should be evaluated on a weekly basis to determine sensor calibration performance. See NEH622.06 for further details on data collection and performance standards.

Sensors that cannot be repaired must be permanently removed from supply stock and be disposed of appropriately.

Responsibilities

The NRCS DCO is responsible for proper data collection at all SNOTEL stations and snow courses in its associated region. The DCO is also responsible for maintenance and ensuring calibration of all sensors at all SNOTEL stations.

The NWCC is responsible for developing data collection standards and sensor maintenance and calibration standards. All standards must be periodically reviewed and adjusted or modified as necessary.

References

U.S. Department of Agriculture, Natural Resources Conservation Service. 2011. National Engineering Handbook, Part 622, Snow Survey and Water Supply Forecasting Handbook. Washington, DC.

Ultrasonic Depth Sensor Specifications. 2011. Judd Communication, LLC, 2010 Salt Lake City, Utah.

Snow Pillow Snow Water Equivalent (SWE) Sensor

Definition

Snow water equivalent (SWE) refers to the amount of water equivalent held in the snowpack. A snow pillow is used to measure SWE.

Purpose

The purpose of this standard is to:

- ensure data quality and consistency of SWE data collected at remote snow telemetry (SNOTEL) stations installed, operated, and maintained by NRCS
- minimize the number of unexpected site visits due to sensor failure

Conditions where this standard applies

This standard applies to snow pillow sensors and snow water equivalent data collected using automated remote SNOTEL data collection stations installed, operated, and maintained by NRCS.

Criteria

- A polypropylene pillow 10 feet in diameter is standard for SNOTEL SWE measurement. Pillows of other sizes or materials may be used in locations as required for reliable data collection.
- Acceptable substitutions for a standard pillow are:
 - Polypropylene pillow 6 or 12 feet in diameter
 - Metal pillow 4 by 5 feet in dimension
- Instances where nonstandard pillows may be required:
 - Locations where snowpack is prone to bridging
 - Locations prone to bear or other animal vandalism
 - Locations prone to extremely heavy snowpacks
 - Locations prone to frost heave or permafrost effects

Snow pillow construction

- Snow pillows must be made of 60-millimeter polypropylene, or other material deemed to perform as well or better.
- Sizes are 6, 10, or 12 feet in diameter, as measured from the center of any of the six sides to the center of the opposite side. A pillow 10 feet in diameter is the SNOTEL standard.
- The top of the pillow must be fitted with one each tank adapter, or equivalent, with plug.
- The opposite sides of the threaded portion of the tank adapter will be cut or ground flat to a depth of three-eighths of an inch from the lip for approximately a half inch along the threaded shank. This provides two flat surfaces that can be gripped by a wrench to facilitate threading and tightening of external plumbing lines. It must be centered on the top of the pillow and be reinforced by two plies of 0.060 (units) polypropylene material.
- The underside inlet must be fitted with one each tank adapter with rubber gaskets.

- The opposite sides of the threaded portion of the tank adapter will be cut of ground flat to a depth of three-eighths of an inch from the lip for approximately half an inch along the threaded shank. This provides two flat surfaces that can be gripped by a wrench to facilitate threading and tightening of external plumbing lines. This adapter is to be located on the bottom panel. Looking from top, the adapter will be located 14 inches in toward the center from a point on the edge which is 26 inches to the left from any corner.
- All seams will be one and a quarter inches minimum scrim lap and seal, with seam flap sealed down on exterior seam edge. No seam should run parallel within 3 inches of any edge. There will be no loose exterior seam edges. Seams will be sealed dielectrically.
- Corners are to be double-folded and double-sealed, diaper type. All exposed scrim and corners must be flood coated and sealed with polypropylene-45 based coating.
- All seams must be inspected visually and any irregularities corrected.
- Each pillow will be air-inflated to 0.25 psi for 12 hours. The entire surface area is to be sprayed or washed with a leak detection solution. No bubbles may appear on any surface or seam while the pillow is inflated. Any irregularities must be corrected.
- Pillows will be folded and prepared for shipment using poly film between all folds and layers to minimize damage to the pillow during shipment.
- A 4- by 4-inch block of Styrofoam will be securely taped over each tank adapter to minimize damage to the pillow during shipment.
- The entire pillow will be encased in a layer of 0.020 (units) PVC or greater, and placed in a cardboard box no smaller than 32 by 32 by 10 inches. Each box will have sufficient wall thickness, durability, and construction to maintain its original shape and integrity during shipment. Boxes will be banded to pallets, no more than two to a pallet for transportation.
- Pallets must not be stacked during shipment.

Installation

- Snow pillows must be installed on a level pad. The pad must be sized according to the slope to mitigate snow creep and glide affects. For slopes greater than 10 percent, the minimum pillow pad must be 25 feet in diameter.
- Snow pillows must be located in a position on the site with the greatest clear sky view. There must not be any vegetative interference obstructing above the snow pillow, typically 30 degrees from vertical, where possible. Carefully consider vegetation removal to ensure the longest possible vegetative steady-state condition (NEH622.04).
- The snow pillow must be located to minimize wind affects.
- Careful consideration must be made to locating the snow pillow in relationship to the shelter. The snow pillow must be located above the shelter floor so that sufficient positive hydraulic head is inside the shelter. The hydraulic head should be at least 10 inches inside the shelter but low enough to prevent over topping of the manometer between recharges.
- Snow pillow size must be a 10-foot polypropylene or equivalent except in the following cases:
 - where frost heave or size constraints are concerns, a 6-foot polypropylene pillow can be used
 - where circumstances dictate the use of steel pillows (e.g., bears, permafrost, environmental considerations)
- The plumbing connection should always be oriented as close to the manometer as possible.

- Snow pillows must be bedded using sand or fine-grained material. Wooden frames may be used in areas such as Alaska, where permafrost or similar conditions require it.
- Where appropriate, snow pillows should be protected from rodents or other types of animals with hardware cloth or equivalent placed beneath and above the snow pillow.
- Where appropriate, snow pillows must be protected by a fence. Install fence in a fashion so that it does not affect snow accumulation or ablation.
- Snow pillows must not be located closer than 3 feet to any fence. If the fence material is dark in color or made from wood, the snow pillow must not be closer than 5 feet to the fence.
- Plumbing lines must be a minimum of three-eighths inch inside diameter. All plumbing materials must be damage resistant, corrosion resistant, flexible, and heavy duty. Copper or various plastic (cross-linked polyethylene (PEX) or equivalent) lines are acceptable.
- The distance between the snow pillow and the shelter should be kept to a minimum, preferably less than 20 feet and not more than 50 feet, except in the most extenuating circumstances.
- The snow pillow manometer should be inside the shelter with the ability to shut-off flow from the gage, as well as to the manometer and, optionally, to the pressure transducer. The manometer tube must be a maximum of 0.5 inches from the measuring tape.
- In areas of frost heave or other instability, pressure transducers may be installed at the base of the snow pillow and connected to the shelter with cable designed to be buried or encased in protective pipe. The transducer should be located inside a watertight box, if possible, to protect the transducer and allow for access.
- Snow pillows must be filled with equal amounts of a standard mix of propylene glycol-ethanol (PGE) and water or denatured ethanol and water. Use an appropriate dye (fluorescein green or rhodamine red) to color the fluid so it can be easily read inside the manometer tube. Ten-foot snow pillows are to be filled with a minimum of 75 gallons of propylene glycol-ethanol mixture and 75 gallons of water or the ethanol-water mixture, for a total of 150 gallons.
- Brass nuts, valves, and fittings must be heavy duty, such as those used in refrigeration systems. Brass, stainless steel, and heavy-duty plastics are allowed. Galvanized or standard pipe fittings are not allowed as they can potentially corrode or contribute to gel formation.
- In cases where overland water flow may occur, a trench must be constructed on the uphill slope, no closer than 3 feet to the pillow and extending around the two pillow sides, terminating away from the pillow or below the elevation of the pillow. This is to ensure that any free water flowing downhill will be diverted away from the snow pillow.
- A minimum of four ground truth sample points must be marked around the snow pillow. These sample points must be installed and permanently numbered. This is to ensure that the ground truth manual measurements do not cause damage to the pillow. This can be done using either two poles with sample points on both sides or four poles marking each sample point location.

Calibration and maintenance

Shop calibration and maintenance

- Snow pillows should be closely inspected for leaks or signs of abrasion that could result in a failure in the pillow material (polypropylene).
- Leaks and abrasions should be repaired with proper materials and retested before installation in the field.
- Shop evaluation and repair must be done by the responsible DCO.

Field calibration and maintenance

Field maintenance and calibration verification procedures must be done at each scheduled site maintenance visit, or once a year.

Field maintenance and calibration verification should be done following methods and specifications described in NEH622.05.

Recordkeeping

Records for maintenance or calibration done in the Electronics Maintenance Facility (EMF) shop will be recorded by the EMF staff. Maintenance and calibration records are to be maintained for the life of each SNOTEL data collection site. Records must be kept of all field and shop procedures and include the maintenance and calibration of each sensor by its serial number. Records must be maintained on official data site forms or site ledgers and entered into the central database.

Data parameters

See NEH622.02 for data parameters associated with snow water equivalent measurements.

Considerations

Environmental conditions at remote sites are highly variable and uncontrollable. Extreme cold, heat, wind, rain, snow, and ice may cause unexpected reactions from the sensor. Unusually harsh conditions may require maintenance and calibration verification be performed more often than specified to ensure data quality.

Inconsistencies in electronic components and mounting configurations can affect sensor performance. Every effort should be taken to recognize any inconsistency that might account for performance problems, and then eliminate the inconsistency when possible.

Plans and specifications

Plans and specifications associated with all SWE sensors considered for use at SNOTEL stations must be in keeping with this standard.

Operation and maintenance

Data from fluid-based SWE sensors should be evaluated on a weekly basis to determine sensor calibration performance. Refer to NEH622.05 for further details on data collection and performance standards.

Sensors that cannot be repaired must be permanently removed from supply stock and be disposed of appropriately.

Responsibilities

The NRCS DCO is responsible for proper data collection at all SNOTEL stations and snow courses in its associated region as well as maintenance and ensuring calibration of sensors at all SNOTEL stations.

The NRCS NWCC is responsible for developing data collection standards and sensor maintenance and calibration standards. All are to be periodically reviewed and adjustments or modifications made as necessary.

References

U.S. Department of Agriculture, Natural Resources Conservation Service. 2011. National Engineering Handbook, Snow Survey and Water Supply Forecasting Handbook. Washington, DC.

Spears Manufacturing Company. 2007. #872-007-3/4 FIPT tanks adapter.

Soil Moisture and Soil Temperature Sensor

Definition

A sensor used to measure the moisture and temperature of the soil. Soil moisture refers to the amount of water that is held in the soil at a given depth. Soil temperature refers to the temperature of the soil at a given depth.

Purpose

The purpose of this standard is to:

- ensure data quality and consistency of soil moisture and soil temperature data collected by NRCS
- minimize the number of unexpected site visits due to sensor failure

Conditions where this standard applies

This standard applies to soil moisture and soil temperature sensors and data collected using automated remote snow telemetry (SNOTEL) data collection stations installed, operated, or maintained by NRCS.

Criteria

Installation

- The minimum, standard depths for placement of soil moisture and soil temperature sensing devices are depths of 2, 8, and 20 inches. Additional standard depths are 4 and 40 inches. Refer to NEH622.04 for more information (fig. 8C-1).
- Soil moisture and soil temperature values must be sampled and reported a minimum of once per day. If only one soil moisture and temperature reading is taken, it must be taken at midnight.
 - Probes should be installed in an undisturbed area, with vegetation and shading representative of the area of interest.
 - Consider topography. Probes should not be installed in depressions, channels, or other water-collecting areas.
 - Probes must be installed away from the influence of the shelter, both shadow and roof runoff.

Figure 8C-1 Standard depths for sensing devices



-
- Probes should be installed away from large vegetation, if possible.
 - Probes must be installed away from the influence of the pillow pad and precipitation gage.
 - Probes must be installed in mineral soil.
 - Probes must be installed away from areas of human disturbance, such as compaction, digging, etc.
 - Probes must be installed horizontally into a vertical, undisturbed soil face, and offset horizontally from each other. The deepest probe may be installed vertically, if necessary.
 - When inserting a probe, a force of 20 kilograms must not be exceeded. Do not jiggle the probe during insertion. Be sure the probe is not contacting rock. A hydra probe jig may be used in very hard or rocky soils.
- Sensor cables must be protected in a buried, UV-resistant conduit, with the end sealed to prevent rodent damage.
 - A drip loop must be created in each sensor cable between the sensor and the conduit to minimize artificial moisture transport.
 - The installation depth must be clearly labeled on both the probe and the end of the sensor cable.
 - At each site where soil sensors are installed, the soil must be described, the soil classification determined, and samples for bulk density must be taken to support the interpretation of soil moisture monitoring data. When possible these activities will occur simultaneously with sensor installation and be performed by qualified personnel. It is recommended that a soil scientist assist in selecting the sensor installation location. The soil probes must not be installed in the evaluation pit.

Calibration and maintenance

Shop maintenance and validation

Specific software or algorithms provided by the manufacturer must be used to check the calibration of the sensor. Data are from raw voltages collected from measurements in media that will provide a known and predictable result.

Temperature readings from sensors must be compared to a calibrated, handheld unit or a mercury-column thermometer. The temperature reading from the sensor must be within ± 3 degrees Celsius of the calibrated thermometer.

Field maintenance and calibration

There are no field calibration or repair procedures for the sensor. Malfunctioning sensors must be replaced. Replacement of sensors must follow installation procedures described in NEH622.04.

Sensors should remain in service as long as they are functioning due to the disturbance that is caused by repeated replacement of sensors.

When fewer than the entire stack of sensors needs to be replaced, it is best to install the sensors in an adjacent location, rather than installing them in the original pit. This prevents disturbance of the good sensors and surrounding soils. Also, the new installation pit should be far enough away from the original pit so as not to disturb the soil or sensors.

All field maintenance and calibration must be documented using standard calibration and maintenance forms.

Recordkeeping

Maintenance and calibration records are to be maintained for the life of each SNOTEL data collection site. Records must be kept of all the field and shop procedures and include the maintenance and calibration of each sensor by its serial number. Records are to be maintained on official data site forms or ledgers and entered into the central database.

Data parameters

See NEH622.02 for data parameters associated with soil moisture and soil temperature measurements.

Considerations

Environmental conditions at remote sites are highly variable and uncontrollable. Extreme cold, heat, wind, rain, snow, and ice may cause unexpected reactions from the sensor. Unusually harsh conditions may require maintenance and calibration verification be performed more often than specified to ensure data quality.

Inconsistencies in electronic components and mounting configurations can affect sensor performance. Every effort should be taken to recognize any inconsistency that might account for performance problems, and then eliminate the inconsistency when possible.

Plans and specifications

Plans and specifications associated with all soil moisture and temperature sensors considered for use at stations must be in keeping with this standard. Maintenance plans must be developed for each SNOTEL data collection station. These plans must be reviewed periodically and adjustments or modifications made as needed.

Operation and maintenance

Data from soil moisture sensors should be evaluated on a weekly basis to determine sensor calibration performance. See NEH622.05 for further details on data collection and performance standards.

Sensors that cannot be repaired must be permanently removed from supply stock and be disposed of appropriately.

Responsibilities

The DCO is responsible for proper data collection at all SNOTEL stations and snow courses in its associated region. The DCO is also responsible for maintaining and verifying calibration of sensors at all SNOTEL stations.

The NRCS NWCC is responsible for developing data collection standards and sensor maintenance and calibration standards. All standards must be periodically reviewed and adjustments or modifications made as needed.

References

Stevens Water Monitoring System, Inc. 2007. The hydra probe soil sensor, comprehensive Stevens hydro probe user's manual.

U.S. Department of Agriculture, Natural Resources Conservation Service. 2011. National Engineering Handbook, Part 622, Snow Survey and Water Supply Forecasting Handbook. Washington, DC.

Solar Radiation Sensor (Pyranometer)

Definition

A pyranometer is a sensor used to measure solar radiation. Solar radiation refers to the energy (electromagnetic radiation) emitted by the sun.

Purpose

The purpose of this standard is to:

- ensure data quality and consistency of solar radiation data collected by NRCS
- minimize the number of unexpected site visits due to sensor failure

Conditions where this standard applies

This standard applies to solar radiation sensors and solar radiation data collected using automated remote snow telemetry (SNOTEL) data collection stations installed, operated, or maintained by NRCS.

Criteria

Installation

- This sensor must be mounted to the meteorological tower using 1-inch galvanized pipe in a horizontal and level configuration.
- The sensor must be placed a minimum of 2 feet away from the tower leg.
- If a snow pillow is installed, the solar radiation sensor must be mounted facing away from the pillow.
- Mounting height for this sensor will vary depending on the amount of anticipated maximum snow depth, if any. Refer to table 8C–3 for solar radiation sensor mounting heights.
- The height of the solar radiation sensor must be recorded in the metadata.

Calibration and maintenance

Shop maintenance and calibration

- All pyranometers must be returned to a certified lab for calibration or testing and recalibration every 3 years.
- Shop calibration must be done following methods and specifications described in NEH 622.05.
- All pyranometers must be checked for signal output and operability.
- All pyranometers must be sent to a certified lab for calibration. Upon return, their calibration data must be entered into the database to be used to correct the readings as they come in from the field.

Table 8C–3 Solar radiation sensor mounting height

Anticipated maximum snow depth	Mounting height of solar radiation sensor
Little or no snow	10 feet above ground level ± 1 foot
10 feet	19 feet above ground level ± 1 foot
20 feet	29 feet above ground level ± 1 foot

Field maintenance and calibration

- Pyranometers must be replaced or have field calibration verification checks performed annually. When replacing a sensor, all installation standards and data verification procedures must be performed. See NEH622.04.
- Field maintenance and calibration checks must be done following methods and specifications described in NEH622.05.
- Calibration checks should be no more than 3 percent variance from previous calibration check, or the sensor should be replaced.
- The reference pyranometer must be an identical model to the field sensor, and certified to be calibrated within manufacturer's specification annually.
- Calibration adjustments through the R^2 multiplier must be done at the EMF shop.
- Sensors that fail the calibration check should be sent to the EMF shop for repair.
- Inspection of the sensor and associated mounting hardware must be conducted annually.
- All field maintenance and calibration should be documented using standard calibration and maintenance form.

Recordkeeping

Records for maintenance or calibration done in the Electronics Maintenance Facility (EMF) will be recorded by the EMF staff. Maintenance and calibration records must be maintained for the life of each SNOTEL data collection site. Records must be kept of all the field and shop procedures and include the maintenance and calibration of each sensor by its serial number. Records must be maintained on official data site forms or ledgers and entered into the central database.

Data parameters

See NEH622.02 for data parameters associated with solar radiation measurements.

Considerations

Environmental conditions at remote sites are highly variable and uncontrollable. Extreme cold, heat, wind, rain, snow, and ice may cause unexpected reactions from the sensor. Unusually harsh conditions may require maintenance and calibration verification be performed more often than specified to ensure data quality.

Inconsistencies in electronic components and mounting configurations can affect sensor performance. Every effort should be taken to recognize any inconsistency that might account for performance problems, and then eliminate the inconsistency when possible.

Plans and specifications

Plans and specifications associated with all pyranometers considered for use at SNOTEL stations must be in keeping with this standard. Maintenance plans must be developed for each SNOTEL data collection station. These plans must be reviewed periodically and adjustments or modifications made as needed.

Operation and maintenance

Data from pyranometer sensors should be evaluated on a weekly basis to determine sensor calibration performance. See NEH622.06 for further details on data collection and performance standards.

Sensors that cannot be repaired must be permanently removed from supply stock and be disposed of appropriately.

Responsibilities

The NRCS DCO is responsible for proper data collection at all SNOTEL stations and snow courses in its associated region. The DCO is also responsible for maintaining and ensuring calibration of sensors at all SNOTEL stations.

The NRCS National Water and Climate Center is responsible for developing data collection standards and sensor maintenance and calibration standards. All standards must be periodically reviewed and adjusted or modified as necessary.

References

U.S. Department of Agriculture, Natural Resources Conservation Service. 2011. National Engineering Handbook, Part 622, Snow Survey and Water Supply Forecasting Handbook. Washington, DC.

Storage Precipitation Gage

Definition

Precipitation refers to moisture falling from the sky to the earth in both liquid and solid forms. A storage precipitation gage is a device designed to catch, measure, and store precipitation during all seasons. Precipitation can be collected and measured regardless of if it falls in liquid or solid form.

Purpose

The purpose of this standard is to:

- ensure data quality and consistency of precipitation data collected by NRCS
- minimize the number of unexpected site visits due to sensor failure

Conditions where this standard applies

This standard applies to storage precipitation gages and precipitation data collected using automated remote snow telemetry (SNOTEL) data collection stations installed, operated, or maintained by NRCS.

Criteria

Installation

- All storage precipitation gages must be constructed consistent with the standard drawings in appendix G of this standard.
- Precipitation gages must not be installed on slopes over 25 percent because of the possibility of snow creep damaging the gage.
- The gage must not interfere with the proper operation of other sensors at the site.
- Precipitation gages must be located relative to the snow pillow (the primary sensor), in the position with the greatest clear sky view. There must be no vegetative interference obstructing above the precipitation gage, typically 30 degrees from vertical, where possible. Carefully consider vegetation removal to ensure the longest, possible vegetation steady-state condition.
- The gage must be anchored to secure footings such as concrete or railroad ties designed to a minimum 25-year life expectancy.
- Concrete footings must be a minimum of 10 inches in diameter, with minimum depths as follows:
 - 24 inches for a 12-foot gage
 - 30 inches for a 16-foot gage
 - 36 inches for a 20+ foot gage
- The gage must be vertical when measured with a standard bubble level.
- The gage must have an alter wind screen mounted with the top of the screen between 1 and 2 inches over the orifice of the gage. Exceptions when an alter wind shield may not be used are:
 - in cases of low snowpack and high winds, a Wyoming screen may be substituted
 - in locations where heavy snow or icing may regularly destroy the shield
 - in locations well shielded by vegetation
- Plumbing lines must be a minimum of three-eighths–inch inside diameter. All plumbing materials must be damage-resistant, corrosion-resistant, flexible, and heavy duty. Copper or various plastic cross-linked polyethylene (PEX) lines are acceptable.

- The distance between the gage and the shelter should be kept to a minimum, preferably less than 20 feet, but not more than 50 feet, except in the most extenuating circumstances.
- The gage height must be a minimum of 4 feet higher than the greatest expected snow depth.
- The precipitation gage manometer should be inside the shelter with the ability to shut off flow from the gage, as well as to the manometer and optionally to the pressure transducer. The manometer tube must be a maximum of 0.5 inches from the measuring tape. The base recharge fluid (manometer height at recharge) level in the manometer must be high enough to read easily (at least 10 in above floor level), and under normal conditions should not exceed 20 inches.
- In areas of frost heave or other instability, pressure transducers should be installed in the base of the precipitation gage and connected to the shelter with a cable designed to be buried or encased in PVC pipe.
- Precipitation gages must be charged with a standard mix of propylene glycol-ethanol (PGE) (equal proportions of propylene glycol-ethanol, with 2 percent Polysorbate 20, and up to 4 percent other additives as desired by the DCO) with a film (approximately ¼- to ½-inch thick) of light, clear mineral oil to prevent evaporation. An ethylene glycol-methanol mixture may be used where dictated by colder temperatures.
- The quantity of recharge fluid is site-specific and dependent on several factors, including:
 - the amount of maximum anticipated annual precipitation as well as winter and spring precipitation
 - the lowest anticipated temperature at the site. Precipitation gages can freeze solid in winter months for many reasons, particularly if the recharge solution is too dilute. A general rule of 1 gallon of recharge per every 8 inches of annual precipitation is recommended. This allows a 25-percent dilution factor in the recharge. A minimum of 4 gallons per site is required in order to completely cover the “J” tube inside the gage and prevent air bubbles in the line.
- Brass nuts, valves, and fittings must be heavy-duty variety, such as those used in refrigeration systems. Brass, stainless steel, and heavy-duty plastics are allowed. Galvanized or standard pipe fittings are not allowed as they can potentially corrode or contribute to gel formation.
- All storage precipitation gages must be painted brown or green, unless another color is dictated by the landowner. This dark color allows for additional heat through solar mechanics in winter, which helps minimize gage freezing. In most cases, it also minimizes the visual impact of the site.
- At the bottom of the gage, a minimum of a three-quarter-inch ball valve or equivalent must be installed and used as the primary drain device.

Calibration and maintenance

Shop calibration and maintenance

The storage precipitation gage must be evaluated for leaks or other damage before installation in the field. Shop evaluation and repair must be done by the responsible DCO for the region.

Field calibration and maintenance

Field maintenance and calibration verification must be done at each scheduled site maintenance visit or once a year.

Field maintenance and calibration verification must be done following methods described in NEH622.05.

Precipitation gages are generally serviced and maintained with an antifreeze solution (equal proportions of propylene glycol-ethanol, with 2 percent Polysorbate 20, and up to 4 percent other additives as desired by the DCO) topped with a layer of light, environmentally safe, industrial oil to prevent evaporation of the solution.

An annual recharging of the gage is recommended, except in areas of extreme remoteness and if the gage is sized to handle multiple years' accumulation of precipitation. Precipitation gages must be recharged before the solution becomes dilute enough to freeze at the coldest anticipated temperature.

Gages should be flushed clean at least once every 3 years. This should be done more often for gages that are prone to large amounts of debris and or bugs falling into the gage.

The area around the precipitation gages should be cleared of trees that might fall and damage the gage. As a general rule (and when practical), a 30-degree window (open to the sky) above the gage should be maintained in all directions ensuring that snow will fall directly on the gage under "nominal" nonwindy conditions.

Gages found to be in need of repair must be replaced or repaired by the responsible DCO.

Recordkeeping

Records for maintenance or calibration done in the Electronics Maintenance Facility (EMF) shop will be recorded by the EMF staff. Maintenance and calibration records must be maintained for the life of each SNOTEL data collection site. Records must be kept of all the field and shop procedures and include the maintenance and calibration of each sensor by its serial number. Records must be maintained on official data site forms or ledgers and entered into the central database.

Data parameters

See NEH622.02 for data parameters associated with precipitation measurements.

Considerations

Environmental conditions at remote sites are highly variable and uncontrollable. Extreme cold, heat, wind, rain, snow, and ice may cause unexpected reactions from the sensor. Unusually harsh conditions may require maintenance and calibration verification be performed more often than specified to ensure data quality.

Inconsistencies in electronic components and mounting configurations can affect the performance of sensor. Every effort should be taken to recognize any inconsistency that might account for performance problems and eliminate the inconsistency when possible.

As vegetation or man-made structural changes occur at or near the station, the performance of the gage may change. When possible, prevent any changes that may affect the way rain and snow accumulates at a site.

Plans and specifications

Plans and specifications associated with all storage precipitation gages must be in keeping with this standard. A standard drawing for a typical SNOTEL storage precipitation gage is in appendix G of this standard. Maintenance plans must be developed for each SNOTEL data collection station. These plans are must be reviewed periodically and adjusted or modified as needed.

Operation and Maintenance

Data from storage precipitation gages should be evaluated on a weekly basis to determine sensor calibration performance. See NEH622.06 for further details on data management and editing standards.

Sensors that cannot be repaired must be permanently removed from supply stock and be disposed of appropriately.

Responsibilities

The NRCS DCO is responsible for proper data collection at all SNOTEL stations and snow courses in its associated region. The DCO is also responsible for maintenance and ensuring calibration of sensors at all SNOTEL stations.

The NWCC is responsible for developing data collection standards and sensor maintenance and calibration standards. All standards must be periodically reviewed and adjusted or modified as needed.

References

U.S. Department of Agriculture, Natural Resources Conservation Service. 2011. National Engineering Handbook, Part 622, Snow Survey and Water Supply Forecasting Handbook. Washington, DC.

Tipping Bucket Precipitation Gage

Definition

Precipitation refers to moisture falling from the sky to the earth, in both liquid and solid forms. A tipping bucket precipitation gage is used to measure liquid precipitation.

Purpose

The purpose of this standard is to:

- ensure data quality and consistency of precipitation data collected by NRCS
- minimize the number of unexpected site visits due to sensor failure

Conditions where this standard applies

This standard applies to tipping bucket precipitation sensors and precipitation data collected using automated remote SNOTEL data collection stations installed, operated, or maintained by NRCS.

Criteria

Installation

- Precipitation gages must be located in the position with the greatest clear sky view. There must be no vegetative or other type of interference obstructing above the precipitation gage, typically 30 degrees from vertical, where possible. Carefully consider vegetation removal to ensure the longest possible vegetation steady-state condition.
- The gage must be attached to a horizontal piece of galvanized pipe at least 1 inch in diameter and a minimum of 2 feet horizontal from the tower. The gage opening must be level. It is acceptable to place the gage on the ground with a secure mounting device that will ensure that the gage does not move and the top of the gage must be level. If the gage is located on the ground, vegetation must be removed so it does not interfere with the collection of precipitation.
- The gage must be vertical when measured with a standard bubble level.
- For a standard SNOTEL installation, the location of the gage must be within the top 3 feet of the tower, not to exceed 20 feet total height.

Calibration and maintenance

Shop maintenance and calibration

- Shop calibration checks must be performed annually when the sensor fails field calibration tests or fails to report good data.
- Shop maintenance and calibration must be done following methods and specifications described in NEH622.05.
- All sensor electrical properties must be bench-tested for performance that is within specifications.
- Calibrations must be performed using the manufacturer-specified procedures, fixtures, and quantities of water for the various makes and models of tipping bucket precipitation gages.
- The gage must be tested and calibrated using manufacturer-specific test fixtures and procedures.
- The gage must be tested to ensure equal amounts of water are required for each throw of the mechanism, followed by factory-designed calibration procedures using manufacturer-specific test fixtures.
- Gages that pass the performance test should be labeled as calibrated with the date of calibration and technician initials.

- All maintenance and calibration procedures should be documented and associated with the serial number of each sensor.

Field maintenance and calibration

- Sensors must be cleaned, inspected, and calibration verified annually, or replaced by a calibrated sensor.
- Field maintenance and calibration verification must be done following methods and specifications described in NEH622.05.
- The gage must be tested to ensure equal amounts of water are required for each throw of the mechanism, followed by factory-designed calibration procedures using manufacturer-specific test fixtures. Measurement should be within ± 1 percent of expected number.
- Sensors that do not pass the calibration check must be removed and replaced.
- Tipping bucket gages that have been removed from the field should be shipped to the Electronics Maintenance Facility (EMF) for repair.

Recordkeeping

Records for maintenance or calibration done in the EMF shop will be recorded by the EMF staff. Maintenance and calibration records must be maintained for the life of each SNOTEL data collection site. Records must be kept of all the field and shop procedures and include the maintenance and calibration of each sensor by its serial number. Records must be maintained on official data site forms or ledgers and entered into the central database.

Data parameters

See NEH622.02 for data parameters associated with precipitation measurements.

Considerations

Environmental conditions at remote sites are highly variable and uncontrollable. Extreme cold, heat, wind, rain, snow, and ice may cause unexpected reactions from the sensor. Unusually harsh conditions may require maintenance and calibration verification be performed more often than specified to ensure data quality.

Inconsistencies in electronic components and mounting configurations can affect the performance of sensors. Every effort should be taken to recognize any inconsistency that might account for performance problems, and then eliminate the inconsistency when possible.

Plans and Specifications

Plans and specifications for tipping bucket precipitation sensors and sensor installation must be in keeping with this standard. Maintenance plans must be developed for each SNOTEL data collection station. These plans must be reviewed periodically and adjustments or modifications made as needed.

Operation and Maintenance

Data from tipping bucket precipitation sensors should be evaluated on a weekly basis to determine sensor calibration performance. See NEH622.06 for further details on data collection and performance standards.

Sensors that cannot be repaired must be permanently removed from supply stock and be disposed of appropriately.

Responsibilities

The NRCS DCO is responsible for proper data collection at all SNOTEL and snow course stations in its associated region. The DCO is also responsible for maintaining and ensuring calibration of sensors at all SNOTEL stations.

The NRCS NWCC is responsible for developing data collection standards and sensor maintenance and calibration standards. All standards must be periodically reviewed and adjusted or modified as needed.

References

Texas Electronics, Inc. 2013. Rain Gauge Tipping Bucket Series 525 specifications.

U.S. Department of Agriculture, Natural Resources Conservation Service. 2011. National Engineering Handbook, Part 622, Snow Survey and Water Supply Forecasting Handbook. Washington, DC.

Wind Speed and Wind Direction Sensors

Definition

Sensors used to measure wind speed and wind direction. Wind speed refers to the speed at which air is moving relative to the Earth's surface. Wind speed is measured in miles per hour (mph).

Wind direction refers to the direction from which the air is moving. Wind direction is measured in degrees azimuth, with 0 and 360 degrees representing north, 90 degrees representing east, 180 degrees representing south, and 270 degrees representing west.

Purpose

The purpose of this standard is to—

- ensure data quality and consistency of wind speed and wind direction data collected by NRCS
- minimize the number of unexpected site visits due to sensor failure

Conditions where this standard applies

This standard applies to all wind speed and wind direction sensors and the data collected using automated remote SNOTEL data collection stations installed, operated, or maintained by NRCS.

Criteria

Installation

- The wind speed and wind direction sensors are mounted on the meteorological tower in a horizontal or vertical configuration, depending on the type of anemometer.
- Mounting height for these sensors varies depending on the amount of anticipated maximum snow depth, if any. Refer to table 8C–4 for wind speed sensor mounting heights.
- When possible, the sensor should be installed in the general direction of the prevailing wind to prevent potential influences from the tower.
- The height of the wind speed and wind direction sensors must be recorded in the metadata.

Wind Speed Sensor Calibration and Maintenance

Shop calibration and maintenance

- Shop calibration checks must be performed at least once every 6 years unless the sensor fails in the field.
- Shop calibration must be done following methods and specifications described in NEH622.05.
- Used sensors must be evaluated for the remaining life expectancy. Sensors with an expected life expectancy of less than 6 years must be sent to the manufacturer for refurbishing or discarded appropriately.

Table 8C–4 Mounting height of wind speed and wind direction sensors based on maximum snow depth

Anticipated maximum snow depth	Mounting height of wind speed and wind direction sensor
Little or no snow	10 feet above ground level ± 1 foot
10 feet	19 feet above ground level ± 1 foot
20 feet	29 feet above ground level ± 1 foot

- The sensor casing and components must be inspected for physical damage or wear.
- The sensor must be cleaned and damage parts repaired.
- All sensors electrical properties must be bench tested for performance that is within specifications.
- All wind speed sensor operation performance must be evaluated for its entire range of measurement (e.g., from 0 to 130 mph).
- Sensor calibration must be checked using a currently calibrated tachometer and data logger.
- Resulting voltage must be monitored with an oscilloscope and compared to rpm. The comparison must be confirmed to be within manufacturer's specifications.
- Resulting calculated wind speed must be within 0.25 mph of manufacturer's corresponding wind speed for specific rotor rpm. Rotors outside of this specification must be replaced.
- Wind speed sensors that pass the performance test, should be labeled as calibrated with the date of calibration and technician's initials.
- All maintenance and calibration procedures should be documented and associated with the serial number of each sensor.

Field calibration and maintenance

- Field maintenance and calibration procedures must be done at least once a year, or the sensor must be replaced with a currently-calibrated sensor.
- When replacing any sensor, all installation standards and data verification procedures must be performed. See NEH622.04.
- Field calibration checks must be done following methods and specifications described in NEH622.05.
- Bearings must be replaced a minimum of once every 2 years or when suspect.
- Calibration checks must be done using a currently calibrated motorized tachometer and data logger. Resulting calculated wind speed must be within ± 2 mph of reference rotation/wind speed.
- All wind speed sensor operation performance must be evaluated for at least three measurements, spanning its entire range of measurement (e.g., from 0 to 130 mph). See NEH 622.05 for complete calibration procedures.
- Wind speed sensors that fail the calibration check must be sent to the NRCS EMF shop for repair.

Wind Direction Sensor Calibration and Maintenance

Shop calibration and maintenance

- Shop calibration checks must be performed every 6 years, unless the sensor fails in the field.
- Shop calibration must be done following methods and specifications described in NEH622.05.
- Used sensors must be evaluated for the remaining life expectancy. Sensors with a life expectancy of less than 6 years must be returned to the manufacturer for refurbishing or discarded appropriately.
- All sensor electrical properties must be bench tested for performance that is within specifications.
- All sensor operation performance must be evaluated for its entire range of measurement (i.e., 0 to 360 degrees azimuth).
- Sensor calibration must be checked using calibrated an oscilloscope, vane angle fixture, and data logger.
- Resulting voltage must be monitored with an oscilloscope and specified voltage for particular angle. The comparison must be confirmed to be within the manufacturer's specification

- Resulting calculated wind direction must be within 0.25 degrees of manufacturer's corresponding wind direction for specific orientation. Rotors outside of this specification must be replaced.
- Sensors that pass the performance test should be labeled as calibrated with the date of calibration and technicians initials.
- All maintenance and calibration procedures should be documented and associated with the serial number of each sensor.

Field calibration and maintenance

- Sensors must be replaced with a calibrated sensor, or field maintenance and calibration procedures must be done at each scheduled site maintenance visit or at least once a year.
- When replacing any sensor all installation standards and data verification procedures must be performed. See NEH622.04.
- Field calibration should be done following methods and specifications described in NEH622.05.
- All wind direction sensors operation performance must be evaluated for its entire range of measurement by recording at least four test positions, one in each of all four azimuth 90-degree quadrants. See NEH622.05 for complete calibration procedures.
- Sensor calibration must be checked using a calibration vane angle fixture, or compass and data logger.
- Resulting calculated wind direction must be within ± 5 degrees of corresponding wind direction for the specific vane orientation. Rotors outside of this specification must be checked and corrected for proper alignment or replaced.
- Sensors that fail the calibration check must be sent to the NRCS EMF shop for repair.

Recordkeeping

Records for maintenance or calibration done in the EMF shop will be recorded by the EMF staff. Maintenance and calibration records must be maintained for the life of each SNOTEL data collection site. Records must be kept of all the field and shop procedures and include the maintenance and calibration of each sensor by its serial number. Records must be maintained on official data site forms or ledgers and entered into the central database.

Data parameters

See NEH622.02 for data parameters associated with wind speed measurements.

Considerations

Several styles and manufacturers of wind speed and wind direction sensors are currently used at SNOTEL stations. Different algorithms are used to convert the raw voltage values or pulse counts to engineering values. The specific algorithm must be used to provide accurate readings. Various manufacturers are acceptable. Examples include: RM Young 5103; Campbell Scientific 0345B, Met One Wind Speed, and Direction sensor. The listing of these sensors by the government does not endorse their use. They are identified here solely as examples of what are currently being used in these networks.

Environmental conditions at remote sites are highly variable and uncontrollable. Extreme cold, heat, wind, rain, snow, and ice may cause unexpected reactions from the sensor. Unusually harsh conditions may require maintenance and calibration verification be performed more often than specified to ensure data quality.

Inconsistencies in electronic components and mounting configurations can affect sensor performance. Every effort should be taken to recognize any inconsistency that might account for performance problems, and then eliminate the inconsistency when possible.

Plans and specifications

Plans and specifications associated with all wind speed and direction sensors considered for use at SNOTEL stations must be in keeping with this standard. Maintenance plans must be developed for each SNOTEL data collection station. These plans must be reviewed periodically, and adjustments or modifications made as needed.

Operation and maintenance

Data from wind speed and wind direction sensors should be evaluated on a weekly basis to determine sensor calibration performance. See NEH622.06 for further details on data collection and performance.

Sensors that cannot be repaired must be permanently removed from supply stock, and be disposed of appropriately.

Responsibilities

The NRCS DCO is responsible for proper data collection at of all SNOTEL stations and snow courses in its associated region. The DCO is also responsible for maintaining and ensuring calibration of sensors at all SNOTEL stations.

The NRCS NWCC is responsible for developing data collection standards and sensor maintenance and calibration standards. All standards must be periodically reviewed and adjusted or modified as needed.

References

Campbell Scientific. 2013. Wind Speed and Direction Sensor 034B specifications. Logan, UT.

R.M. Young Company. 2005. Wind monitor model 05103 specifications. Traverse City, MI.

U.S. Department of Agriculture, Natural Resources Conservation Service. 2011. National Engineering Handbook, Part 622, Snow Survey and Water Supply Forecasting Handbook. Washington, DC.

Data management standards and specifications provide requirements for naming sites and sensors in order to ensure consistent storage and retrieval of data. Data management also includes how to validate, quality control, and further manage data to ensure data can be accessed as needed.

This appendix contains the following standards and specifications:

- Data Management
- Station and Sensor Metadata Management
- Water and Climate Information System Management

Data Management

Definition

Data are collected automatically from remote snow telemetry (SNOTEL) stations, or manually from snow courses, aerial markers, and other sources. Data management includes:

- Data retrieval—The process of collecting climatic data from automated and manual sources in the Snow Survey and Water Supply Forecasting (SSWSF) Program.
- Data storage—The process of storing resource and climatic data from automated and manual sources.
- Data validation—The physical examination of collected data to ensure the data meet preset conditions, or the determination of whether that data represent a true condition for that data station.
- Data editing—The correction and revision of data so that they represent the conditions and events encountered by the collecting mechanism (manual or automated) during that period.
- Data quality control—The process of ensuring data are reviewed and meet sound hydrologic principles.

Purpose

The purpose of this standard is to ensure consistent, accurate, timely, and reliable retrieval and storage of data.

Conditions where this standard applies

As it relates to data quality, retrieval, and storage, this standard applies to all data collected by NRCS either manually or through the SNOTEL network in association with the SSWSF Program.

As it relates to data validation and editing, this standard applies to all snow water equivalent (SWE), snow depth, cumulative precipitation, and maximum, minimum, and average air temperature data collected by NRCS through the SNOTEL system. Data collected using other sensors are subject to varying degrees of quality control procedures depending on the specific use of that information.

Criteria

Data retrieval

SNOTEL

- SNOTEL stations must provide data in a format that is compatible to the current database protocol at the National Water and Climate Center (NWCC). Refer to NEH622.06.
- Data must be retrieved in near real-time.
- Data from meteor burst stations must flow from remote station, to master station, to data management workstation (Dynamic Data Distributor or D3), to the Water and Climate Information System (WCIS) server for storage. Other methods of telemetry must be approved by the NWCC.
- Data must be transmitted in the standard, sensor group configuration, described in the following section.

Sensor groups

Group 1—Consists of standard SNOTEL sensors including depth sensors, secondary pillow or precipitation sensors, and battery information. If there are both a secondary pillow and a secondary precipitation sensor, then place in same order as the primary pillow and precipitation sensor.

Group 2—Consists of soil moisture sensors up to four depths. Only use for first four depths of soil moisture unless there are no soil moisture sensors, but there are nonstandard sensors that may include wind speed, wind direction, solar radiation, barometric pressure, relative humidity, or others (table 8D-1).

Group 3—Consists of the fifth depth of soil moisture sensor. If there is a fifth depth for soil moisture then this group is to be used for only soil moisture. If there is not a fifth soil moisture depth, then this group may be used for additional sensors, such as nonstandard sensors' hourly data. Do not leave an empty group (table 8D-2).

Group 4—Nonstandard sensors

Group 5—Nonstandard sensors previous 24 hours

Notes:

- If a sensor or sensors do not exist at a site, move labels up to fill in vacant channels. Example: If there is no depth sensor at a site, move any secondary pillow and secondary battery labels up one channel so that channel 8 is filled.
- Only fill group 3 with labels for the fifth soil moisture sensor, unless there is not a fifth soil moisture sensor and there are other additional sensors.
- Fire weather sensors: The order of the fire weather labels should follow that shown in example 2.

Manual

- Data must be entered using tools that have been approved by the NWCC. Refer to NEH622.06.
- Data from NRCS manual sites and other meteorological data collection networks must be entered by the fourth working day of every month.

Table 8D-1 Example 1: Standard SNOTEL with four soil moisture sensors

Channel	Group 1	Group 2
1	Battery (radio)	1st (soil moisture)
2	Primary pillow	1st (soil temperature)
3	Primary precipitation	1st (soil salinity)
4	Current temperature	1st (dielectric constant)
5	Maximum temperature	2nd (soil moisture)
6	Minimum temperature	2nd (soil temperature)
7	Average temperature	2nd (soil salinity)
8	Depth	2nd (dielectric constant)
9	Second pillow (if needed)	3rd(soil moisture)
10	Secondary precipitation (if needed)	3rd (soil temperature)
11	Maximum radio battery voltage	3rd (soil salinity)
12	Second battery voltage (if needed)	3rd (dielectric constant)
13	Maximum data logger voltage	4th (soil moisture)
14	Data logger lithium voltage	4th (soil temperature)
15		4th (soil salinity)
16		4th (dielectric constant)

Table 8D-2 Example 2: Standard SNOTEL with five soil moisture sensors and a fire weather sensor

Channel	Group 1	Group 2	Group 3	Group 4	Group 5
1	Battery (radio)	1st (soil moisture)	5th (soil moisture)	Wind speed hourly average	Maximum temperature
2	Primary pillow	1st (soil temperature)	5th (soil temperature)	Wind direction hourly average	Minimum temperature
3	Primary precipitation	1st (soil salinity)	5th (soil salinity)	Wind speed hourly maximum	Average temperature
4	Current temperature	1st (dielectric constant)	5th (dielectric constant)	Solar radiation hourly average	Wind speed prev. 24 hour average
5	Maximum temperature	2nd (soil moisture)		Relative humidity hourly maximum	Wind direction prev. 24 hour average
6	Minimum temperature	2nd (soil temperature)		Relative humidity hourly average	Wind speed prev. 24 hour maximum
7	Average temperature	2nd (soil salinity)		Barometric pressure current	Solar radiation prev. 24 hour average
8	Depth	2nd (dielectric constant)		Tipping bucket pcp hourly accumulation	Relative humidity prev. 24 hour maximum
9	Second pillow (if needed)	3rd (soil moisture)			Relative humidity prev. 24 hour average
10	Second precipitation (if needed) including tipping bucket total	3rd (soil temperature)			Tipping bucket pcp prev. 24 hour accumulation
11	BMAX	3rd (soil salinity)			
12	Second battery (if needed) CR10x	3rd (dielectric constant)			
13	BMAX (cr10x)	4th (soil moisture)			
14	LBAT (if needed)	4th (soil temperature)			
15		4th (soil salinity)			
16		4th (dielectric constant)			

Data storage

SNOTEL

- Data must be stored near real-time in a Water and Climate Information System (WCIS) relational database.
- Raw data, as received by the master station, are stored as sampled, with master station receipt and database insert times.
- In instances where data with the same date and time are received, only the first reading received will be stored.
- Raw data will have an initial flag assigned showing the results of the initial quality control (e.g., S–Suspect, V–Valid, and N–No profile). Refer to WCIS Data Flag Definitions for more information.
- Stations must be defined in WCIS, as documented in Station and Sensor Metadata Management Standards and Specifications in NEH622.08.
- Converted data must be stored in the WCIS database.
- Data retrieved that are more than 14-days-old are not stored automatically. Data from these sites will have to be verified and possibly stored manually by operations personnel.
- Converted data are stored in a precision that is standard for each specific data parameter and sensor. See the appropriate sensor standards in NEH622.02.
- Data are rounded according to the established SSWSF Program method. Refer to SSWSF Program Rounding Method in NEH622.06, Data Management, for a complete description of the rounding method.
- The cumulative precipitation on October 1, 00:00 reading will be duplicated and inserted as September 30, 23:59, making it the final reading of the water year. The cumulative precipitation value will then be zeroed with an offset change for the October 1, 00:00 record automatically.
- All meteor burst-formatted data logs will be kept for the current and previous water year (so data can be reprocessed if necessary; e.g., wrong site ID).
- The station must be defined in a WCIS database as stated in the Station and Sensor Management Standards, for the data to map to the correct site and element.

Manual

- Data must be stored in a WCIS database.
- The station must be defined in WCIS as stated in the Station and Sensor Management Standards for the data to map to the correct site and element.

Data Validation/Editing

- Achievable quality data are defined as the value of the best measure or estimate of actual conditions at the remote station and are based on a combination of manual ground truth measurements, manometer readings, and amount of editing that needs to be done.
- Data must be validated on a daily basis during the normal 5-day work week or on the first work day following a weekend or holiday.
- Data must be preliminarily edited within 7 calendar days of its collection during the water supply forecasting season.
- Data must be brought to achievable quality by February 1 of the following water year.
- Preliminary edits to the SNOTEL 00:00 or 00:01 data readings for snow water equivalent (SWE), cumulative precipitation (PREC), air temperature (TMAX/TMIN/TAVG), and snow depth (SNWD) must be completed at

least once a week. Daily edits or estimates are required to ensure product quality, if the SNOTEL station's data are used in a daily hydrologic simulation model during the period of operation.

- The following general rules apply to the sensors:
 - SWE
 - † no negative values
 - † increases should be compared to PREC and SNWD values
 - † decreases should be compared to temperature values
 - PREC
 - † water year precipitation begins at 0.0 inches at 00:00 on October 1. Water year precipitation ends at 23:59 on September 30.
 - † no negative values
 - † never decreases
 - TMAX/TMIN/TAVG
 - † if TMAX, TMIN, and TAVG are equal to each other, they must be verified
 - † $TMAX \geq TAVG \geq TMIN$
 - † No more than three consecutive days of the same temperature value without verification
- SNWD
 - † no negative values
 - † increases should be compared to SWE and PREC
 - † decreases may occur during settling of snowpack after a storm
 - † erroneous maximum readings may represent fog, rain, or snow, and should be evaluated
- Other sensors
 - † Other sensors (wind speed, soil moisture, soil temperature, etc.) have varying degrees of quality control editing procedures applied, depending on the specific use of that information. Nominal quality control should be the establishment of a profile for the sensor.
- Transducer changes—When a transducer is changed at a SNOTEL site, the data editor must review the previous reading and the current reading to make appropriate edits. Offset changes may need to be applied at the same time.
- Offset changes—When a change in a sensor offset is applied, appropriate data edits must be made to maintain consistency in the data string.
- If a site misses the midnight report poll, an estimated value must be entered for:
 - snow water equivalent (SWE)
 - cumulative precipitation
 - snow depth
 - maximum, minimum, and average air temperature
- If a site is down for an extended period, the data editor should use sound hydrometeorological and statistical principles to estimate data. Methods of estimating data are addressed in NEH622.06, Data Management.

- Whenever possible, ground truth data and shelter manometer readings should be used to verify telemetered data.
- On February 1, the station data will be designated as final and each nominal data value will be flagged as final. All achievable quality data must be completed prior to February 1. Refer to the Snow Survey Sampling Guide (Agriculture Handbook No. 169) for quality control criteria for manual snow course data.

Data quality control

- An initial validation screening is automatically applied to data received from the SNOTEL station using the sensor profiles assigned to each station.
- At a minimum, profiles containing validation limits must be developed and implemented for:
 - snow water equivalent
 - cumulative precipitation
 - snow depth
 - maximum, minimum, and average air temperature
 - any other element requiring automated quality control
- Each profile will have upper, lower, increase, and decrease parameters where appropriate.
- Each profile will be developed using historical data when available or scientific estimations if needed.
- The WCIS validation process will flag each value according to the SSWSF flagging policy. Refer to WCIS Data Flag Definitions for more information.
- Authorization to modify data will be controlled by permissions as defined in the Station and Sensor Metadata Management Standard and Specification.
- Preliminary edits to the SNOTEL data (00:00 or 00:01) reading for SWE, cumulative precipitation, air temperature, and snow depth must be completed at least once a week. Daily edits or estimates are required if the SNOTEL station's data are used in a daily hydrologic simulation model.
- When sensor component changes which affect the data quality are made, the responsible data collection office (DCO) is required to make the appropriate sensor modifications in the database prior to the change or within the fourth working day after the change, to ensure accurate data conversion.
- NRCS manual data must be verified and entered by the third working day of every month.
- When a sensor definition is determined to be incorrect after data has been stored, and if the correction would result in a different converted value, then a retroactive correction to a sensor record must be done and the appropriate algorithm will be applied to the raw data set with concurrence from the appropriate DCO.
- Thirty-year averages must be recalculated after any data correction.
- All station data stored in the database will be archived for historical purposes.

Considerations

Data storage

Storage utilizes the time and precision standards and NWCC rounding method. Refer to NEH622.06, Data Management, for time and precision standards and rounding method.

Data validation and editing

Sources of errors in data collected by the SNOTEL network include, but are not limited to;

-
- small variations from one reading to the next (flutter) caused by temperature differences, sensitivity and resolution of measuring devices, or nonconstant sensor supply voltages
 - limitations of the sensing devices (such as capping of the precipitation gage during extremely heavy snowfall events)
 - weather phenomenon and snowpack physics (including frost heave, ice lenses, snow creep, etc.) which result in erroneous readings
 - sensor failure (leaks in precipitation gage, snow sensors, etc.)

Data quality control

- data from other hydrometeorological data collection networks are subject to source agency quality control
- profiles containing validation limits should be reviewed and modified as necessary after climatic extremes

Responsibilities

The DCO is responsible for data quality control, manual station data retrieval, and data validation and editing for all stations within its region.

The NWCC Information Systems Branch is responsible for maintaining WCIS and providing tools to ensure:

- the ability to apply data quality control
- timely automated data retrieval and storage

References

U.S. Department of Agriculture, Natural Resources Conservation Service. 2011. National Engineering Handbook, Part 622, Snow Survey and Water Supply Forecasting Handbook. Washington, DC.

U.S. Department of Agriculture, Natural Resources Conservation Service. 1984. Agriculture Handbook Number 169, Snow Survey Sampling Guide. Federal Snow Survey Sample Guide.

U.S. Department of Agriculture, Natural Resources Conservation Service. 2012. WCIS Data Flag Definitions. National Water and Climate Center. Portland, OR.

Station and Sensor Metadata Management

Definition

Station and sensor metadata management is the process of uniquely identifying, naming, adding, and changing information for individual SNOTEL stations and snow courses, and sensors associated with stations within the Water and Climate Information System (WCIS). In addition to SNOTEL and snow course data, WCIS also contains data from non-WCIS networks such as the U.S. Geological Survey (USGS), National Weather Service (NWS), and U.S. Bureau of Reclamation (BOR).

Purpose

The purpose of this standard is to provide criteria for managing station and sensor identification information, and maintaining current and historical station and sensor configuration information, in order to ensure consistent and accurate storage and identification of the associated station and sensor data.

Conditions where this standard applies

This standard applies to all snow course data and SNOTEL data collected by NRCS within the SSWSF Program. It also applies to the data from non-WCIS networks.

Criteria

Station

- All new SNOTEL stations and manual snow courses must be approved through the SSWSF Program new site approval process before being added to the WCIS database. To accomplish this, the data collection office (DCO) personnel must complete a “New Snow Survey Data Collection Site Approval” form outlining their intent to install a new SNOTEL site. The DCO is responsible for filling out the top section of the form. The correspondence is sent to the WCS group leader with a copy to the NWCC director. The WCS group leader will assign the appropriate hydrologist to complete the initial analysis.
- The WCS forecast hydrologist must perform a basin analysis. If the new installation includes SC/AM (snow course/aerial marker) conversion, the hydrologist must perform a statistical analysis of the relationship between the existing SC/AM and the historical forecast point (if applicable) to determine likelihood of improvement to water supply forecast model(s). The forecast hydrologist must report on the analysis with recommendations to the DCO supervisor.
- The DCO staff must coordinate the recommendations of the forecast hydrologist and field reconnaissance information, make the final decision of location of the new installation, and provide clear justification that the site is valuable for addressing the primary resource concern.
- The DCO must submit new site metadata. This includes the basin hydrologic unit code (HUC) and a request for a frequency ID if it is a SNOTEL station.
- NWCC must request a Weather Service ID to be added to the NWS system.
- The NWCC/WCM group leader must request an National Telecommunication and Information Administration (NTIA) license.
- The SNOTEL database manager must assign a site ID and input available metadata into the WCIS database, and ensure that the site is entered into all appropriate databases, products, and reports.
- At the time a station is entered into the database, permissions for administrative access must be assigned to the appropriate DCO personnel.
- SNOTEL and snow course stations need a unique, alphanumeric ID, called the ACTON ID. This is assigned by the DCO personnel and follows a prescribed grid identification pattern. The naming convention for the ACTON ID is “GGTNN,” where GG is degrees west minus 100, T is a letter representing latitude starting with A at 49 degrees and decrementing by 1 degree until U at 32 degrees, and NN is a sequential number representing the nth station to be added to the latitude/longitude box.

- Each SNOTEL station name must be unique within the entire SNOTEL network.
- Manual snow course names must be unique within a State.
- Non-WCIS sites must have an ID that is unique to the source network, USGS for instance. For NWS sites, the ID is unique to the source network and state. The naming convention for these IDs is set by the target networks.
- Station information that must be stored, in addition to site name and State, are:
 - county
 - elevation in whole feet
 - latitude and longitude in degrees to five decimal places
 - datum, which should be NAD83 for new stations
 - station start date
 - physical and reported time zones
- The status (active, discontinued, or removed) of remote SNOTEL stations and manual snow courses must be stored in the WCIS database.

Data descriptions

- For each type of data collected at a site, there must be a data description associated with the data. This includes:
 - element being collected (e.g., snow water equivalent)
 - collection interval (e.g., daily or monthly)
 - start and end date of reports by that element at that site
 - instrument and method used to collect the data

SNOTEL sensors

- At SNOTEL sites the sensors used to measure data must be defined.
- The sensor definition must include information for converting raw data to sensor data values.
- For a given station, each sensor must also be unique by group and numeric channel for a specified time interval to determine where it is stored in the database.
- For a given station, each sensor must be unique by element, reporting interval, height, and ordinal for a specified time interval.
- Historical sensor configuration information must be stored in the WCIS database for each station from date of installation.

Responsibilities

The DCO is responsible for maintaining information on sensor configuration changes for its region.

The NWCC Information Systems Branch is responsible for managing the initial station sensor information upon installation of new SNOTEL sites.

References

U.S. Department of Agriculture, Soil Conservation Service. 1984. Agriculture Handbook No. 169, Snow Survey Sampling Guide.

U.S. Department of Agriculture, Natural Resources Conservation Service. 2011, National Engineering Handbook, Part 622, Snow Survey and Water Supply Forecasting Handbook. Washington, DC.

U.S. Department of Agriculture, Natural Resources Conservation Service. 2011. New snow survey data collection site approval form.

Water and Climate Information System Management

Definition

The Water and Climate Information System (WCIS) is the primary database on which NRCS stores and serves hydroclimatic data collected in association with the Snow Survey and Water Supply Forecasting (SSWSF) Program. Server backups of WCIS data provide failover capability in case of lost data or disaster recovery.

Purpose

WCIS server backups provide failover capability in the event of lost data or disaster recovery thereby ensuring the continuity of the applications used to provide snow survey and water supply forecasting data to users as needed.

Conditions where this standard applies

This standard applies to the Water Climate Information System maintained and operated by NRCS to serve Snow Survey and Water Supply Forecasting Program data.

Criteria

- Server backups must be performed and stored offsite according to the schedule outlined in NEH622.06, Data Management.
- The minimum number of weekly backup sets is defined in NEH622.06, Data Management.
- Server backups must include the following:
 - System configuration files
 - WCIS applications
 - Operations log files
 - Databases
 - Data log files
 - User files

Responsibilities

The NWCC Information Systems Branch, in conjunction with OCIO International Technology Services (OCIO-ITS), is responsible for ensuring WCIS backups are scheduled and completed as required.

References

U.S. Department of Agriculture, Natural Resources Conservation Service. 2011. National Engineering Handbook, Part 622, Snow Survey and Water Supply Forecasting Handbook. Washington, DC.

The System Performance standards and specifications provide minimum requirements for snow telemetry (SNOTEL) station performance and SNOTEL systemwide performance. Performance in this case describes the reporting percentages for individual sites and for the system as a whole.

This appendix contains the following standards and specifications:

- SNOTEL Remote Station Performance
- SNOTEL Systemwide Performance

Remote Station Performance

Definition

Remote station performance is a measure of how well a snow telemetry (SNOTEL) data collection station is performing. It is measured by the response time of a station to the midnight data request from the master station. Other performance measures are downtime and data stability. The data must be determined to be within the standard criteria for the data type.

Purpose

This standard provides criteria against which a station can be compared to determine whether acceptable performance standards are being met and, if not, to identify deficiencies and problems in order to get the station back in operation.

Conditions where this standard applies

This standard applies to all SNOTEL stations installed, operated, or maintained by NRCS.

Criteria

- Response to the midnight nominal poll: Each remote station should, at a minimum, respond to a poll once each 24-hour period, at midnight. Each remote station must respond to at least 90 percent of the midnight polls. The response percentage is calculated based on the response of a station for a period of 15 consecutive days, which would normally be the last 15 days.
- Downtime: Maintenance and repair schedules should be coordinated to prevent a station from being inoperative more than 15 consecutive days or more than 30 days total in a year, as resources and staff safety allow.
- Data stability: All sensor data must perform to the accuracy as stated in Appendix C, Sensor Standards.

Considerations

Instances where performance standards cannot be met should be documented and copies sent to the Snow Survey and Water Supply Forecasting Program Manager and NWCC director. Information provided should include the site problem, why the site cannot be repaired now, the impacts of lost data, and when the site should be repaired.

Responsibilities

The NRCS data collection office (DCO) is responsible for proper data collection at all SNOTEL stations in its associated region. The DCO is also responsible for documenting and addressing performance issues associated with data collection. Data collection standards must be periodically reviewed and adjustments or modifications should be made as needed.

References

U.S. Department of Agriculture, Natural Resources Conservation Service. 2011. National Engineering Handbook, Part 622, Snow Survey and Water Supply Forecasting Handbook. Washington, DC.

Systemwide Performance

Definition

Systemwide performance standards are the minimally acceptable levels of operation of the NRCS networks.

Purpose

This standard provides criteria against which all or part of the system can be compared to determine whether acceptable performance standards are being met and, if not, to identify the deficiencies and problems.

Conditions where this standard applies

This standard applies to all SNOTEL remote stations and master stations installed, operated, or maintained by NRCS.

Criteria

- The group of stations being examined must have responded to the midnight request for data at the average rate of 90 percent of stations successfully reporting during that time.
- Statistics must be compiled on a daily basis, but averaged over at least 15 days to avoid bias caused by sporadic meteor burst, E layer characteristics, or other short-term communications problems.
- Included in the statistics must be all active stations within the area of consideration, including those with infrequent response characteristics, hardware failure, and low battery levels. The number of stations within the group which are nonfunctional due to “hard” failure (i.e., totally nonreporting for some reason) should not exceed 5 percent of the total.
- Instances where performance standards cannot be met must be documented and copies sent to the NWCC director.

Responsibilities

Systemwide performance will be monitored by the National Water and Climate Center (NWCC) and adjustments or modifications will be made as needed.

References

U.S. Department of Agriculture, Natural Resources Conservation Service. 2011. National Engineering Handbook, Part 622, Snow Survey and Water Supply Forecasting Handbook. Washington, DC

The Forecasting standards and specifications provide requirements for water supply forecasting activities performed as part of the Snow Survey and Water Supply Forecasting Program.

This appendix contains the following standards and specifications:

- Water Supply Forecast

Water Supply Forecast

Definition

A water supply forecast is a prediction of streamflow volume that flows past a point on a stream during a specified season, typically in the spring or summer. Water supply forecasts enable users to plan for efficient water management.

Purpose

This standard provides criteria for establishing, terminating, and documenting forecast points developed and issued by the Snow Survey and Water Supply Forecasting (SSWSF) Program.

These criteria ensure that all forecast points established and maintained by the program are properly justified and documented, and that all forecasts issued by the SSWSF Program meet minimum quality requirements.

Conditions where this standard applies

This standard applies to all locations for which NRCS develops water supply forecasts, from the time of forecast point initiation until a forecast point review reveals that the point no longer meets these criteria.

Criteria

General

The following criteria for documentation must be met at the time of forecast point initiation.

- The responsible data collection office (DCO) supervisor or State water supply specialist (WSS) has identified and met with the individual or entity responsible for resource management who is requesting the forecast to identify the purpose, need, and opportunities associated with the forecast point.
- The needed forecast type has been determined (e.g., seasonal volume, full hydrograph, peak date, peak flow, threshold, or recession flow).
- The model type and frequency of forecasting will be identified and documented. These can include standard monthly statistical models, daily statistical models, simulation models, or some combination of these.
- The feasibility of the proposed forecast in terms of meeting the specific criteria as listed below has been established.
- All metadata have been documented and recorded in the appropriate database.

Specific

- The forecast point must be located at an identified, active stream-gaging station.
- If there are upstream reservoirs, diversions, or other water management activities, these must be identified, and data sources for these reservoirs, diversions, or other activities must be available if possible.
- Monitoring stations available to provide the necessary hydrometeorological input data for forecasting models must be identified and documented.
- At least ten years of concurrent, observed streamflow and hydrometeorological input data must exist.
- The forecast models must be capable of meeting the minimum accuracy requirements as given in the standard and specification for the forecasting method being applied.
- Forecast models developed must be documented to include information such as data sites used (and rationale), error statistics, and other pertinent information to give a full description of the forecast models.

-
- Documentation for all stations (data or forecast) must include the following as a minimum:
 - Station network ID
 - Station name
 - Country
 - State or province
 - County code
 - County name
 - Precise latitude
 - Precise longitude
 - Network name
 - 8-digit HUC
 - Element
 - Elevation
 - SHEF ID
 - In-service date
 - Out-service date
 - If a forecast review determines that an established forecast point no longer meets these criteria and there is no documented request from cooperators to continue providing forecasts for this point, it should be discontinued within a period of no more than 5 years.

Considerations

Full documentation and minimum accuracy standards ensure that each forecast point and each forecast issued have complete and accessible information and meet minimum quality requirements. This is important in maintaining product quality and in continuity of operations when personnel change.

Responsibilities

The NRCS data collection office (DCO) is responsible for proper data collection at all SNOTEL stations in the associated region. Data collection standards must be periodically reviewed and adjustments or modifications made as needed.

References

U.S. Department of Agriculture, Natural Resources Conservation Service. 2011. National Engineering Handbook, Part 622, Snow Survey and Water Supply Forecasting Handbook. Washington, DC.

The table contains an alphabetical listing of the standard drawings in this appendix. CAD drawings for many of these drawings are available from the National Water and Climate Center.

Table 8G-1 Standard drawings

Title

Aerial marker

Federal snow sampler

SNOTEL data sign

SNOTEL shelter

Snow course marker

Storage precipitation gage

Figure 8G-1 Standard drawings

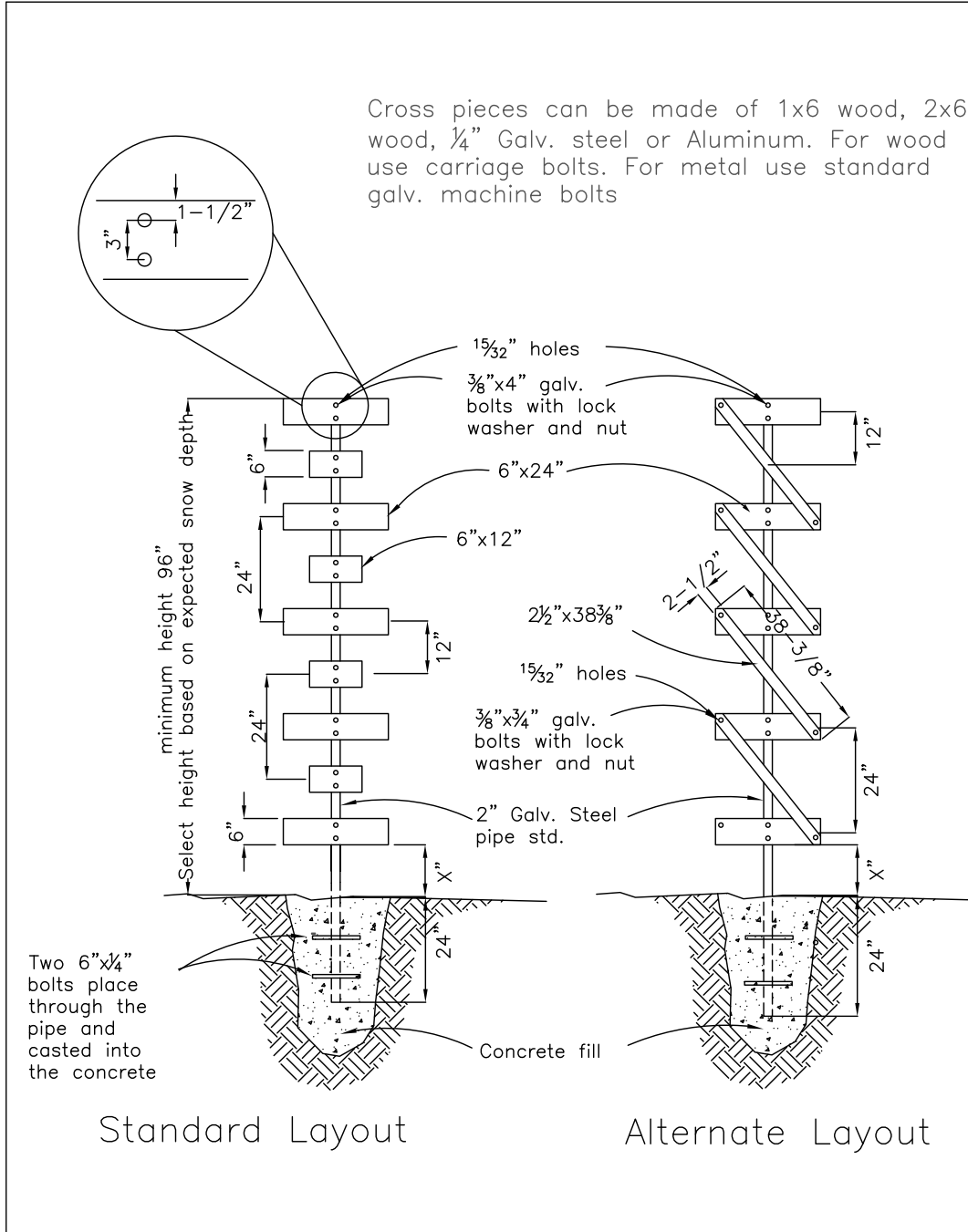

Designed _____	Date _____	CAD FILE NAME _____	Standard & Alternate Aerial Snow Course Marker Design
Drawn C Prestwich	06/2012	DRAWING NO. _____	
Checked _____	_____	SHEET 1 OF 1	
Approved _____	_____	U.S.D.A. NATURAL RESOURCES CONSERVATION SERVICE	

Figure 8G-2 Federal snow sampler, 1 of 10

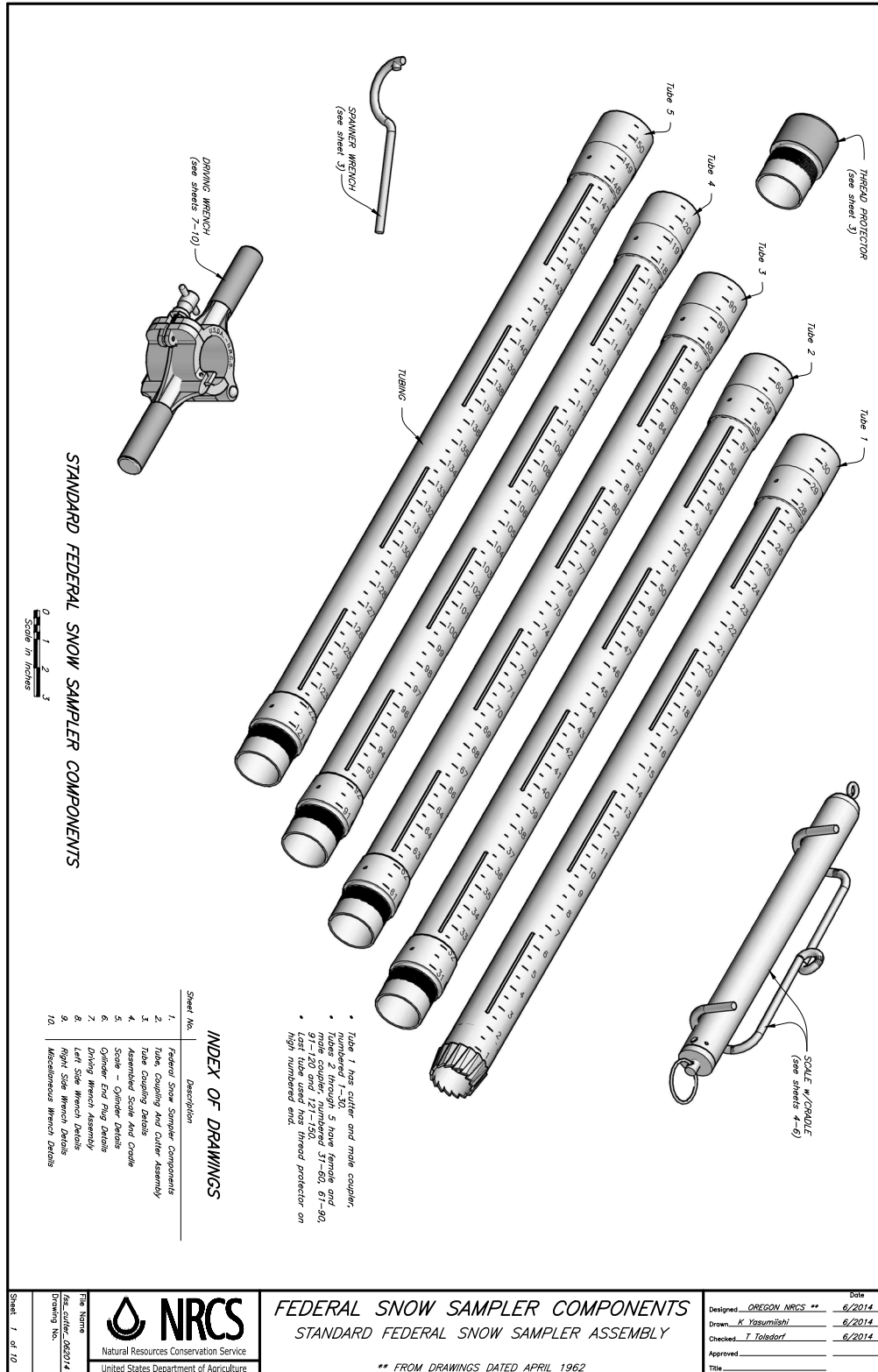
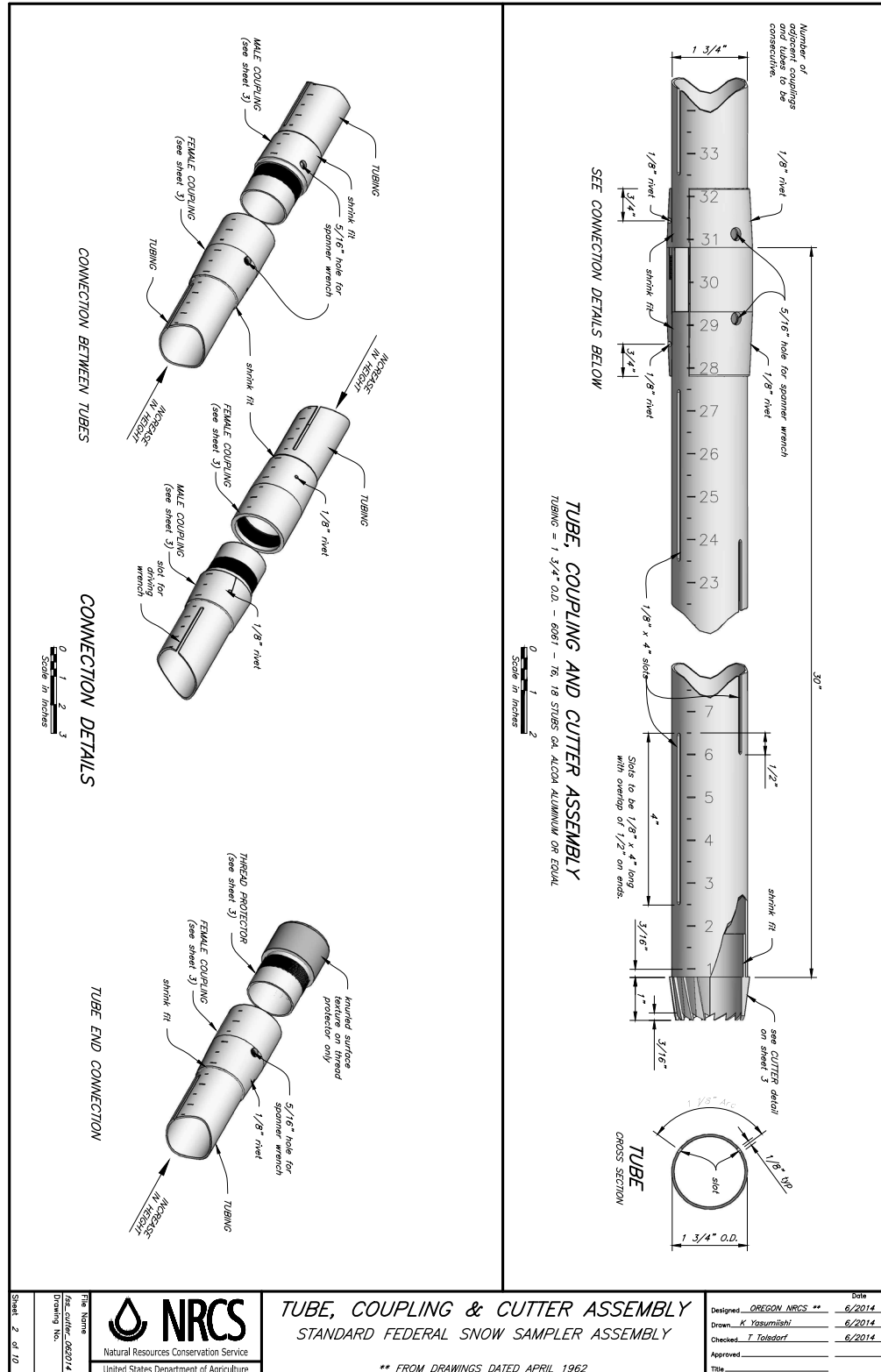

Figure 8G-2 Federal snow sampler, 2 of 10—continued



<p>NRCS Natural Resources Conservation Service United States Department of Agriculture</p>	<p>File Name: TUBE, COUPLING & CUTTER ASSEMBLY</p> <p>Reason: STANDARD FEDERAL SNOW SAMPLER ASSEMBLY</p>	<p>Date: 6/2014</p> <p>Designed: OREGON NRCS **</p> <p>Drawn: K. Yasumishi</p> <p>Checked: T. Tolstedt</p> <p>Approved:</p> <p>Title:</p>
	<p>Drawing No. 062014</p>	<p>** FROM DRAWINGS DATED APRIL 1962</p>
	<p>Sheet 2 of 10</p>	

Figure 8G-2 Federal snow sampler, 4 of 10—continued

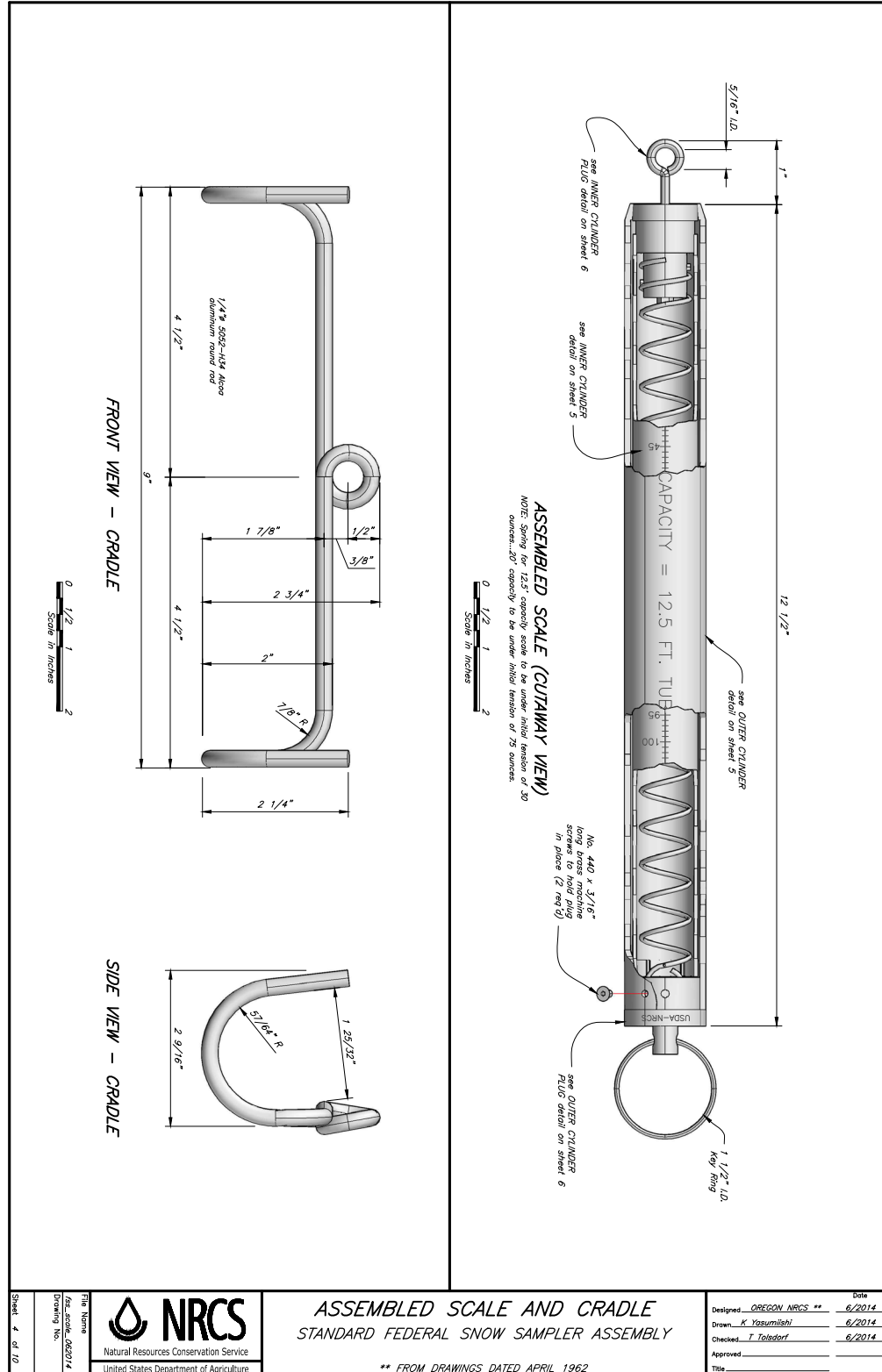

Figure 8G-2 Federal snow sampler, 6 of 10—continued

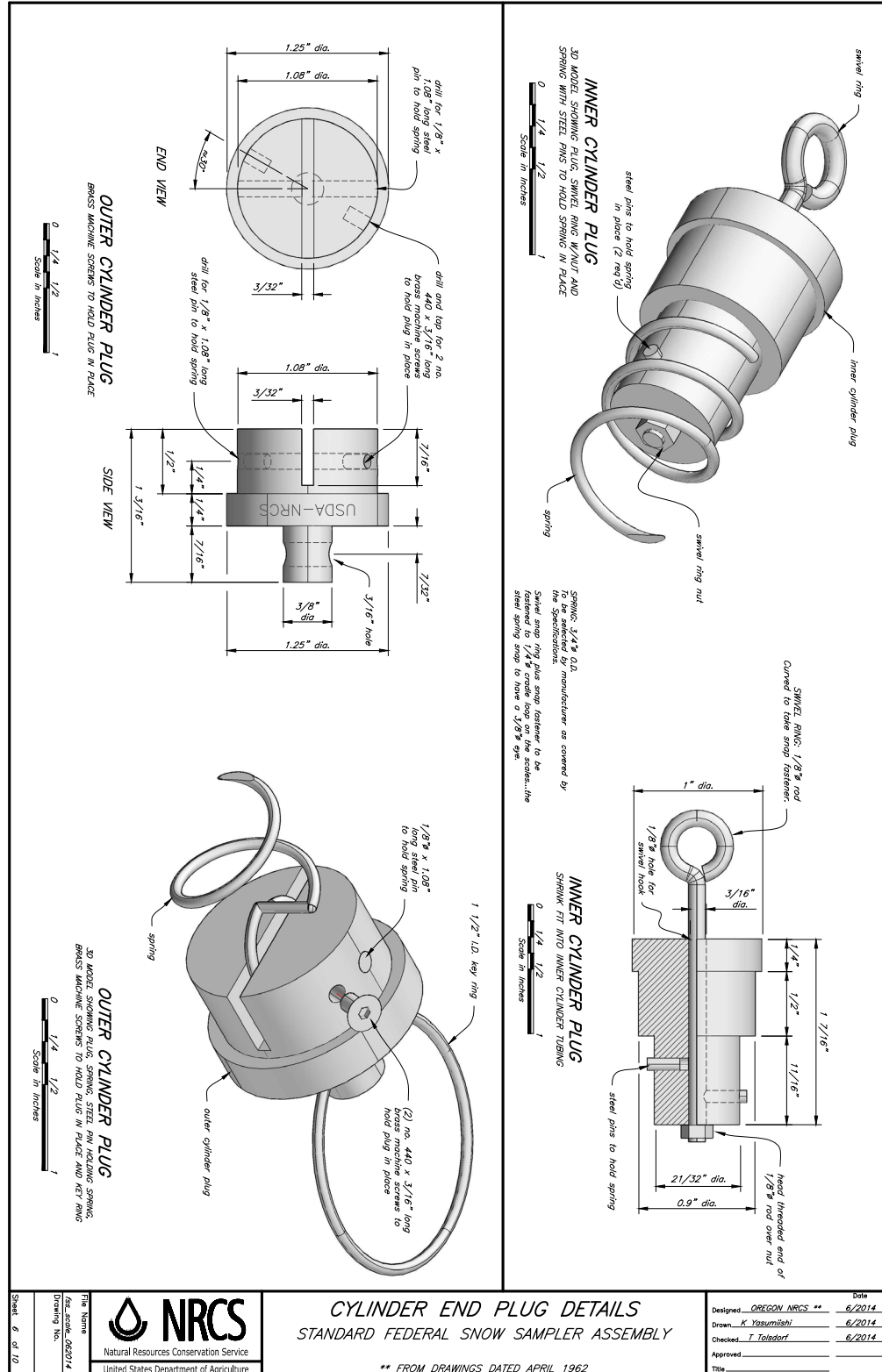

Figure 8G-2 Federal snow sampler, 7 of 10—continued

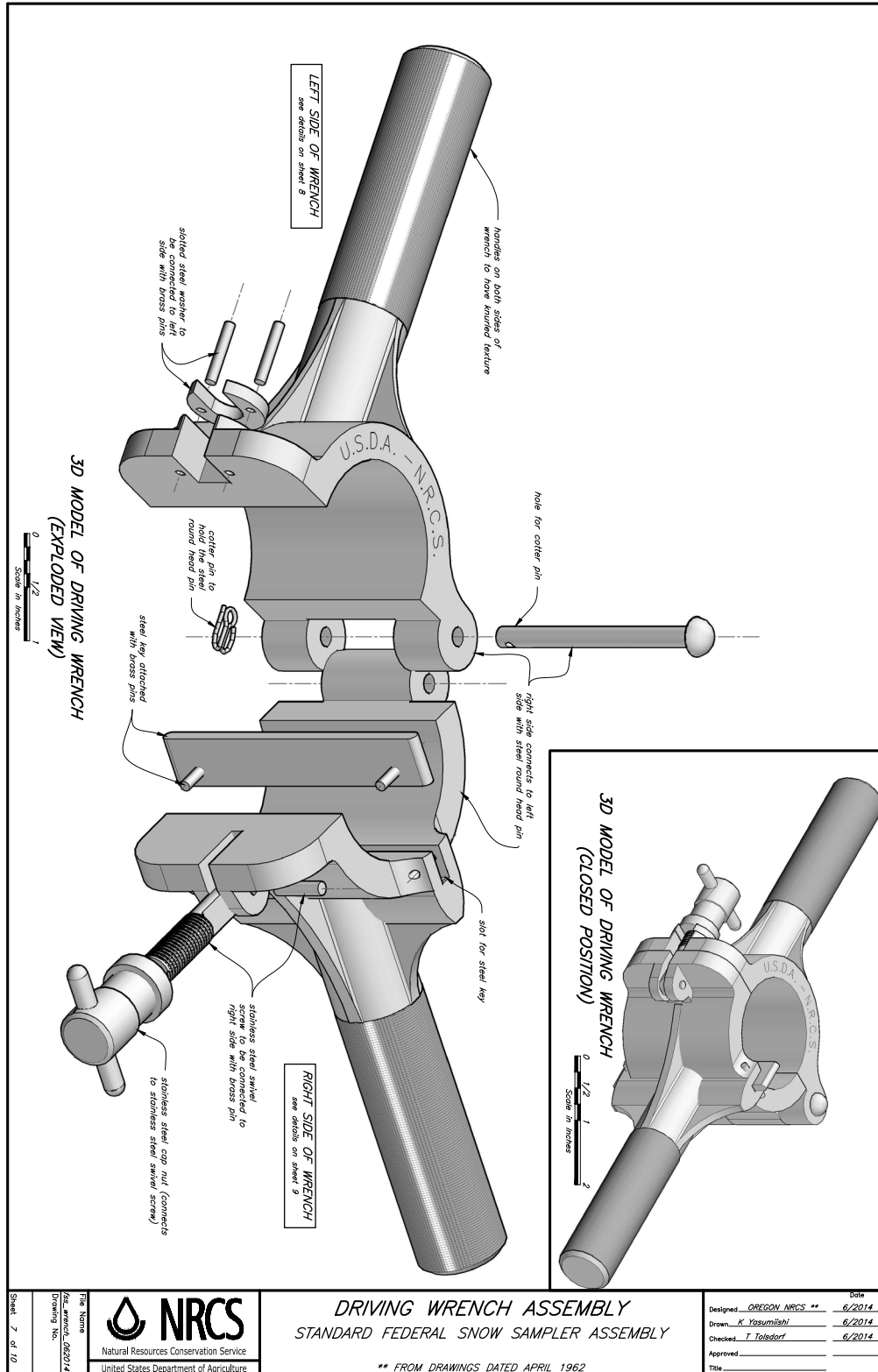

Figure 8G-2 Federal snow sampler, 8 of 10—continued

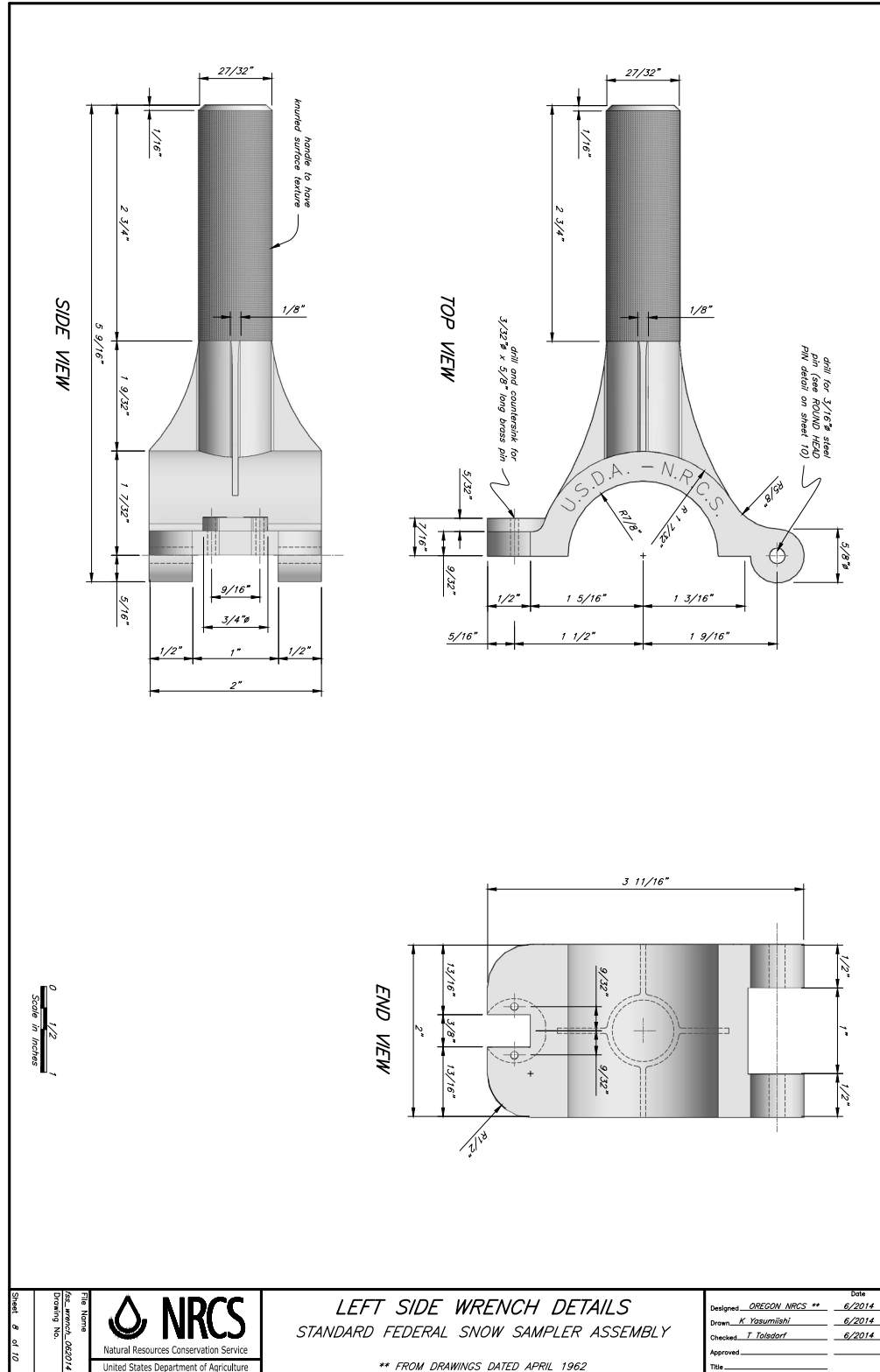

Figure 8G-2 Federal snow sampler, 9 of 10—continued

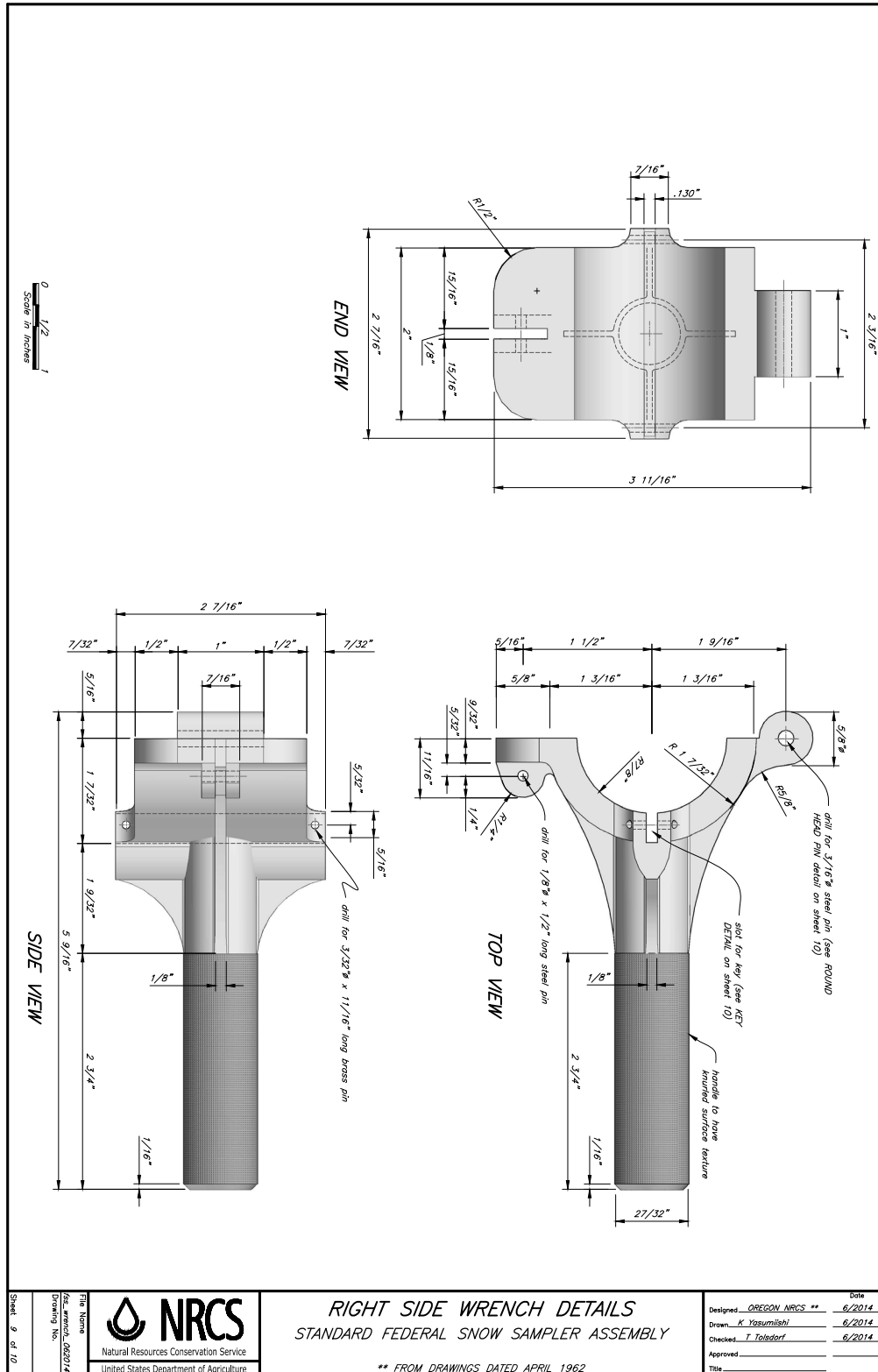

Figure 8G-2 Federal snow sampler, 10 of 10—continued

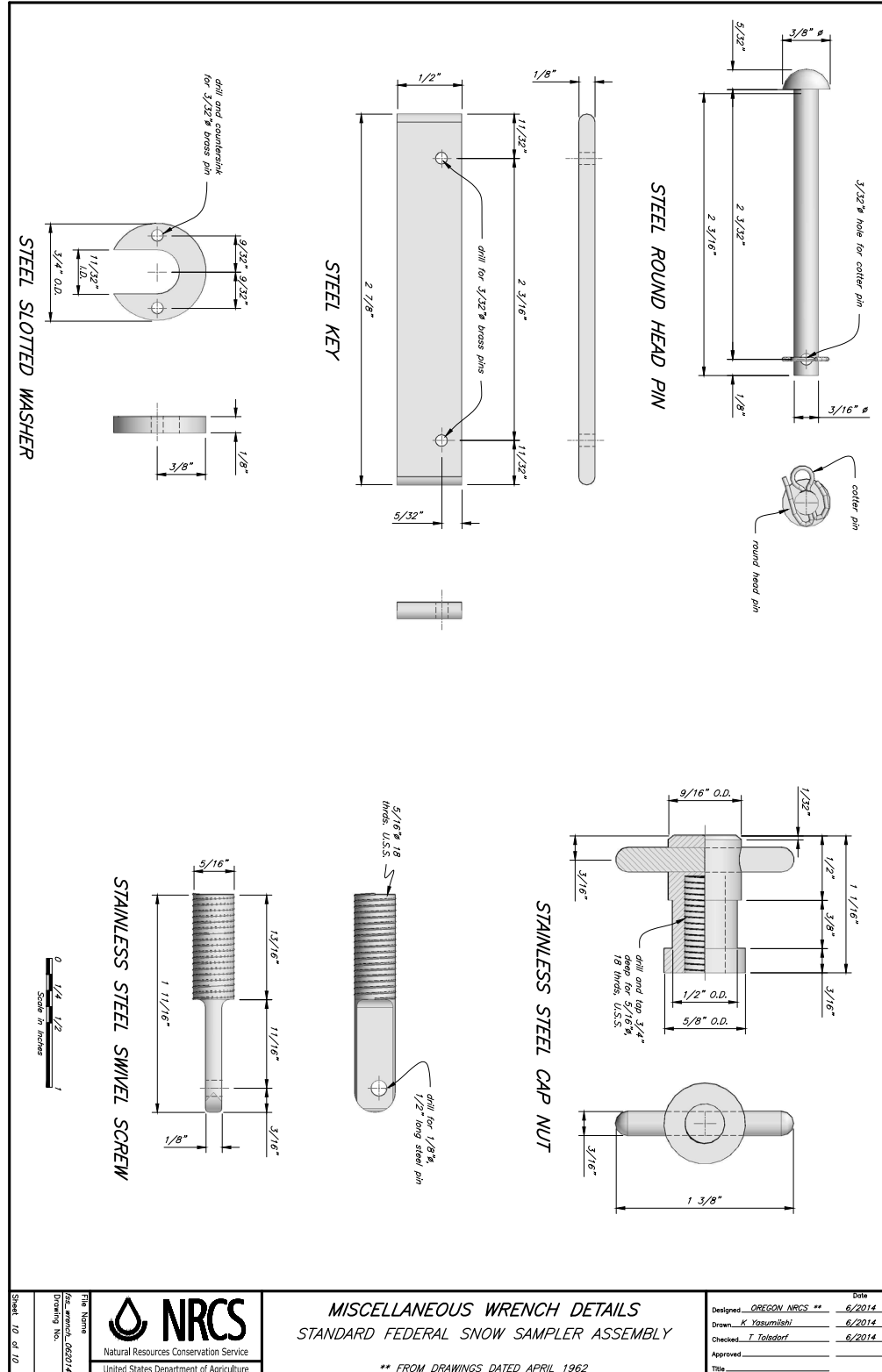

Figure 8G-3 SNOTEL data site sign

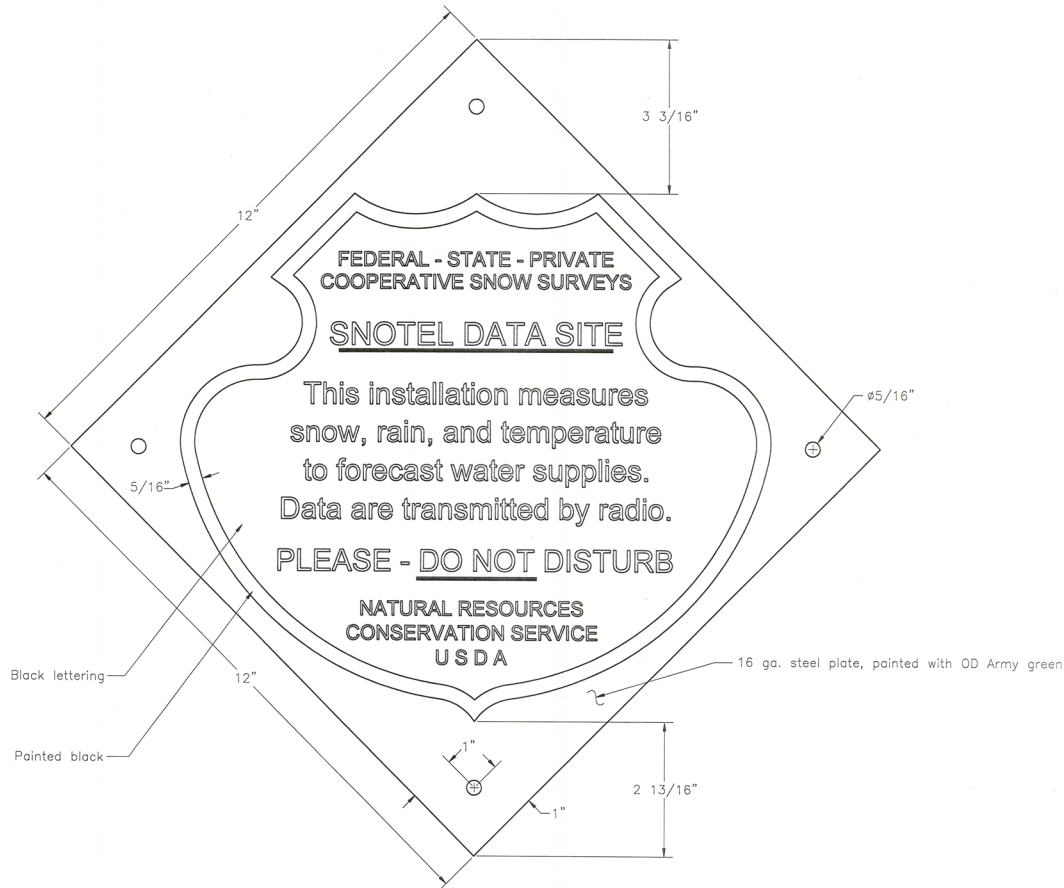

Figure 8G-4 SNOTEL shelter, 1 of 13

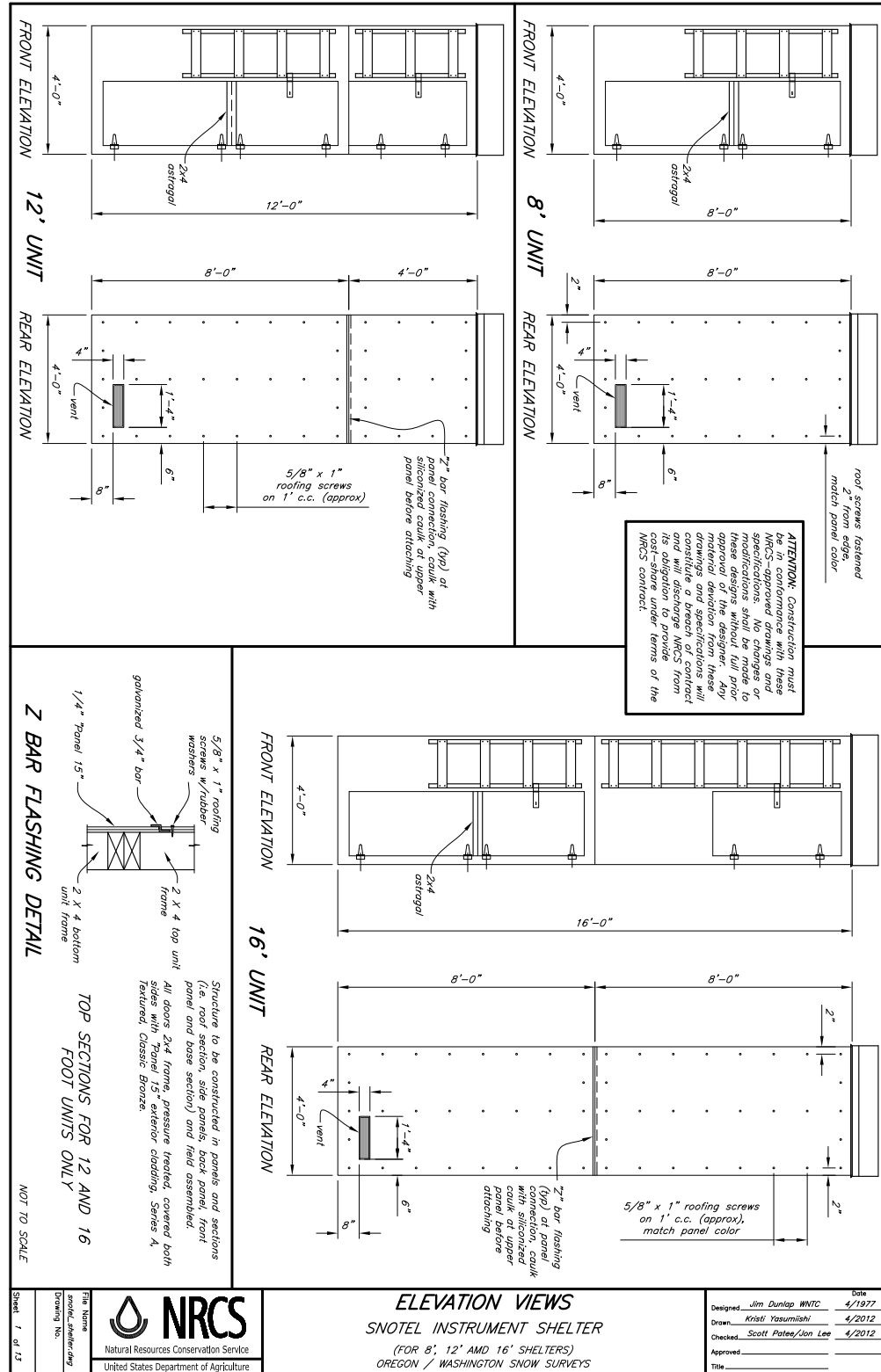

Figure 8G-4 SNOTEL shelter, 2 of 13—continued

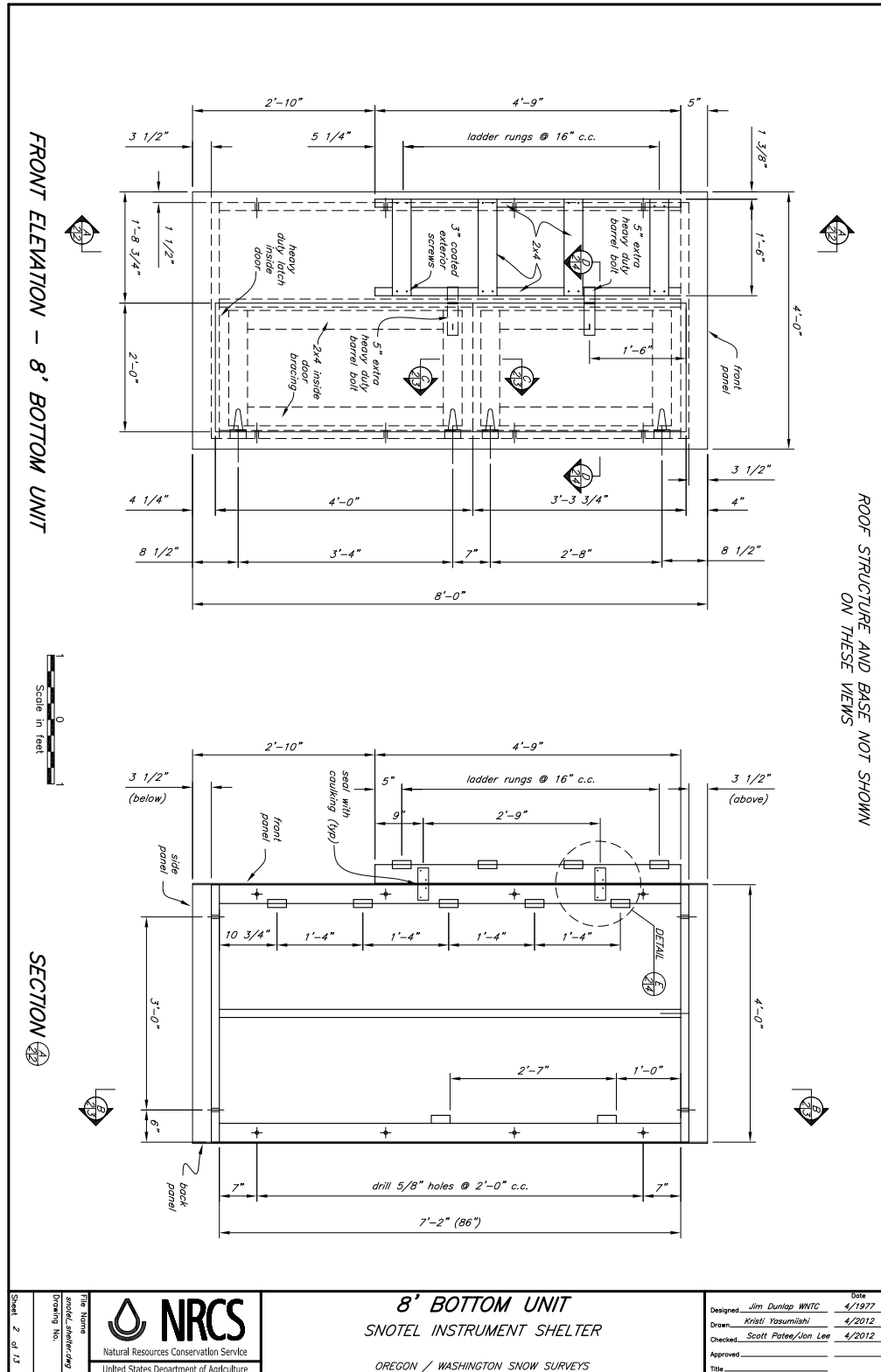
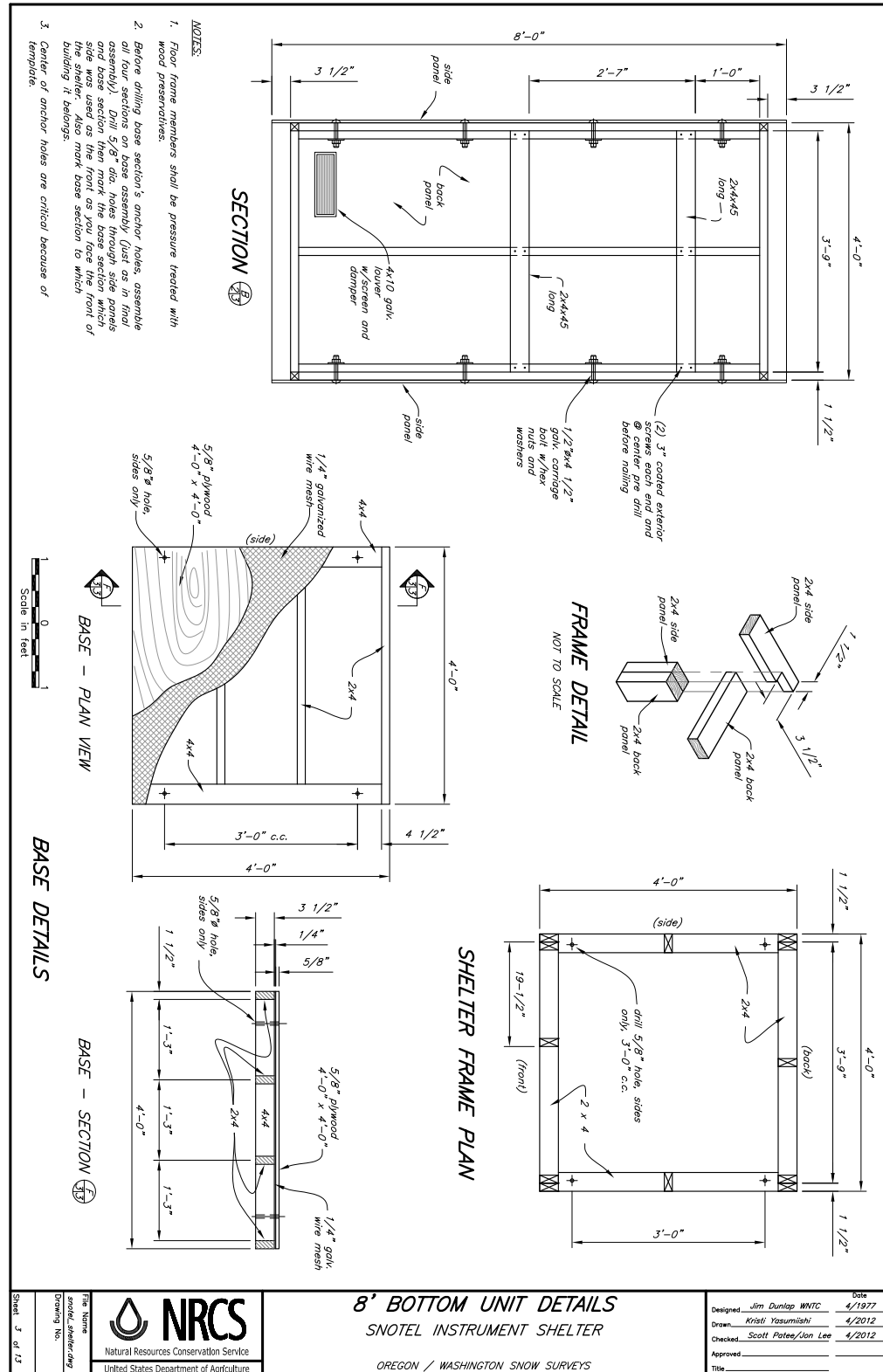

Figure 8G-4 SNOTEL shelter, 3 of 13—continued



8' BOTTOM UNIT DETAILS
SNOTEL INSTRUMENT SHELTER



File Name: snotel_shelter.dwg
Drawing No.:
Sheet: 3 of 13

Designed	Jim Dunlap WNTC	Date	4/1977
Drawn	Kristi Yasumishi		4/2012
Checked	Scott Patee/Jen Lee		4/2012
Approved			
Title			

OREGON / WASHINGTON SNOW SURVEYS

Figure 8G-4 SNOTEL shelter, 4 of 13—continued

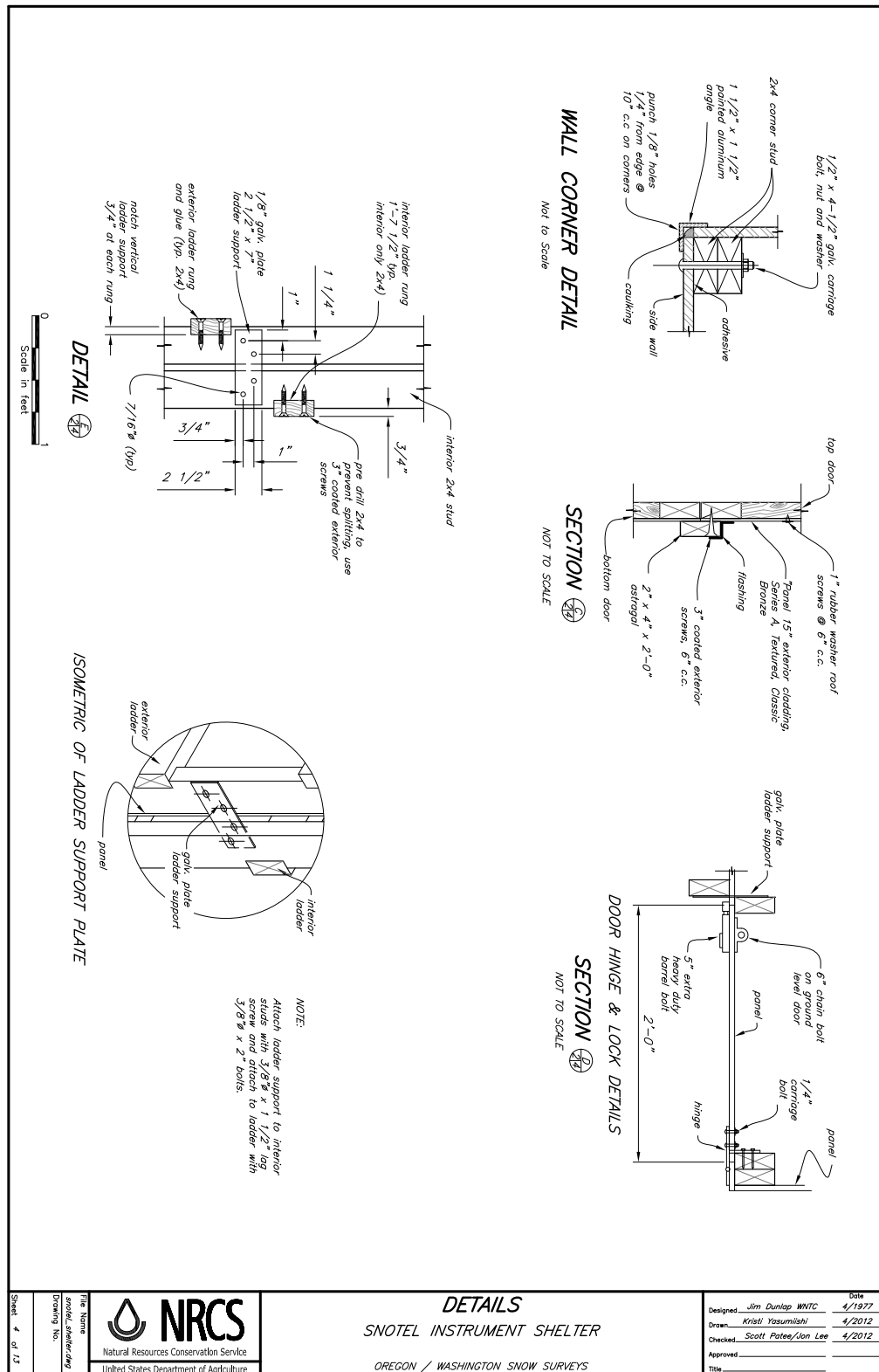

Figure 8G-4 SNOTEL shelter, 5 of 13—continued

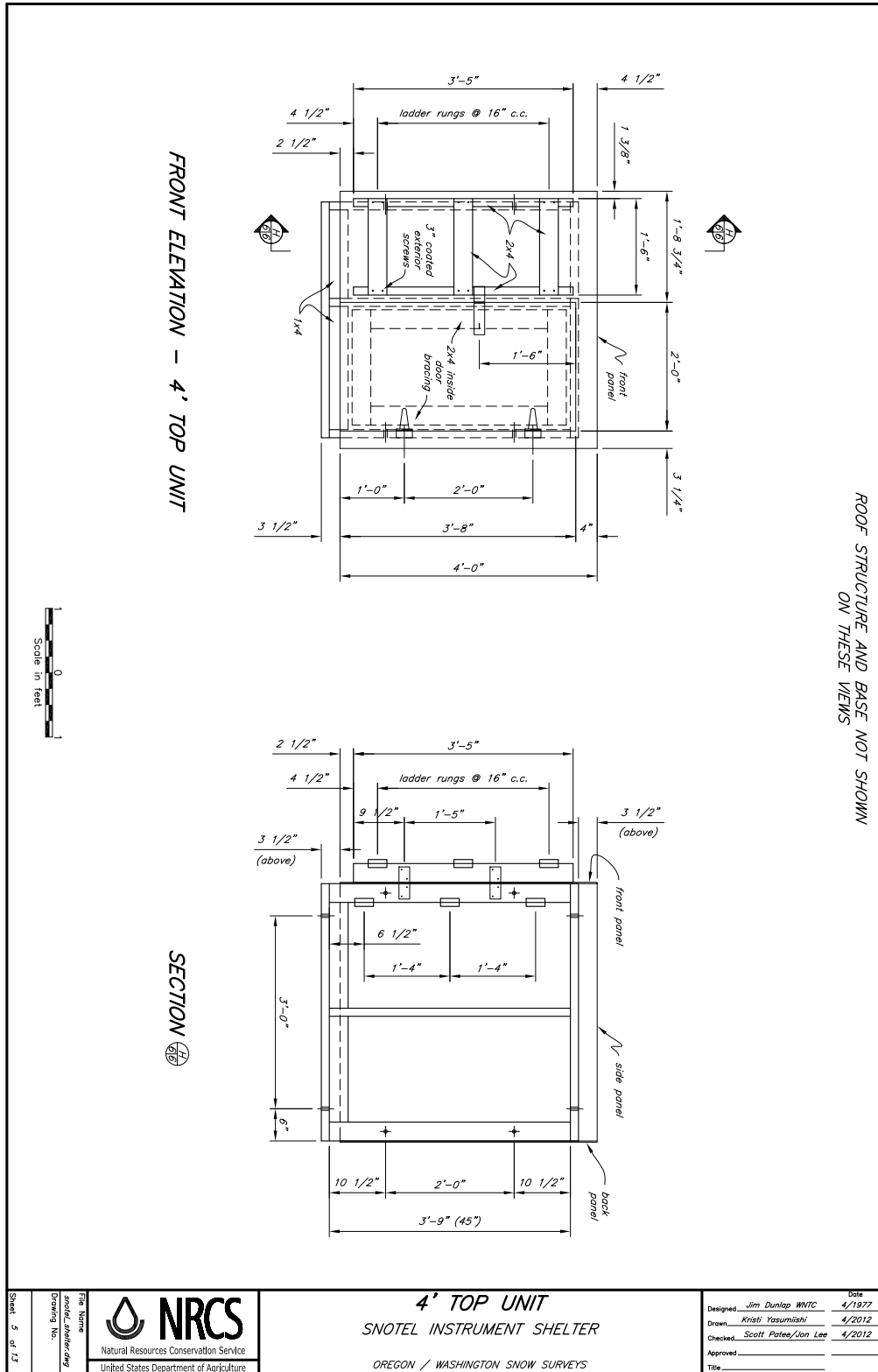

Figure 8G-4 SNOTEL shelter, 6 of 13—continued

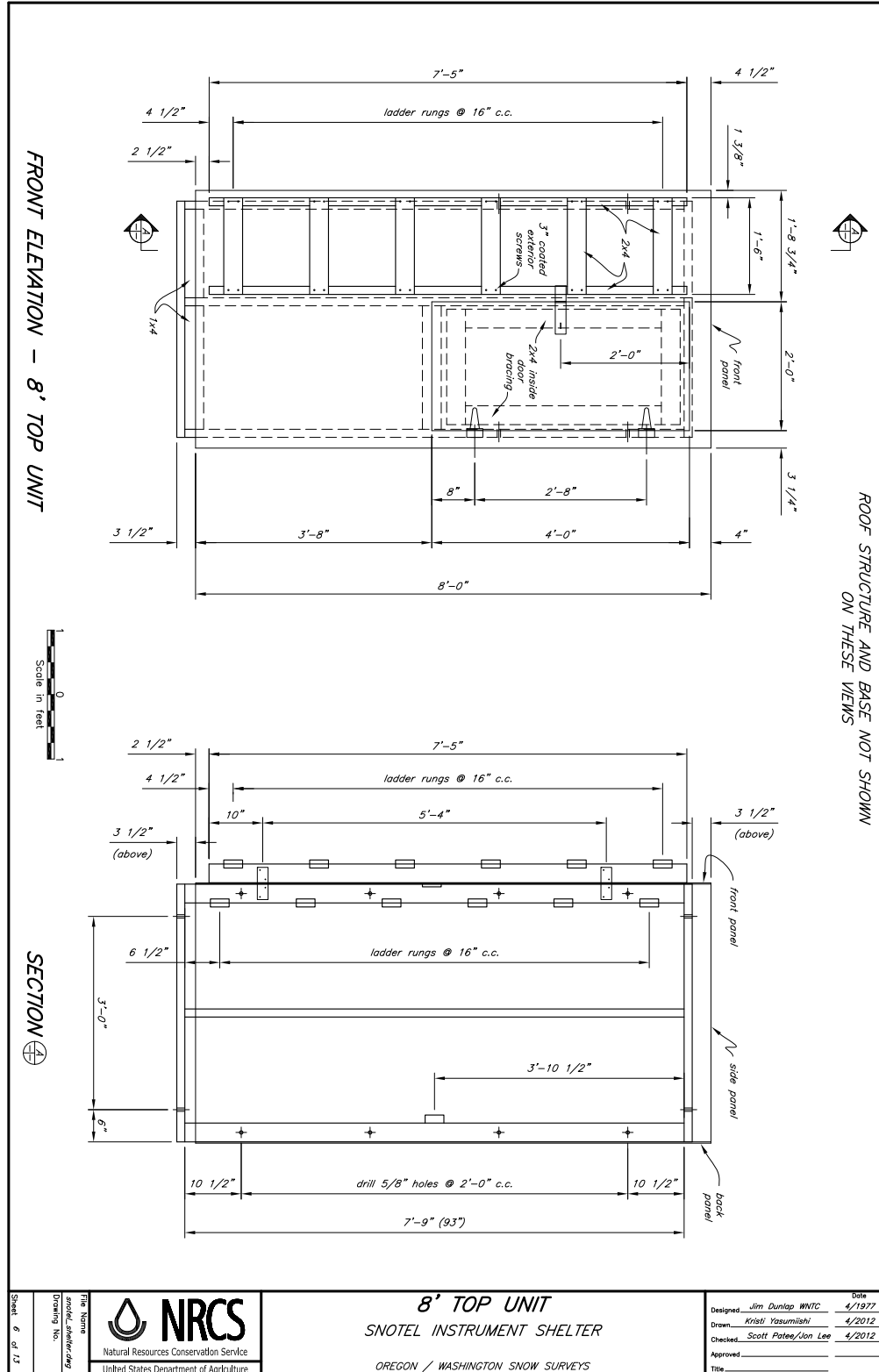

Figure 8G-4 SNOTEL shelter, 7 of 13—continued

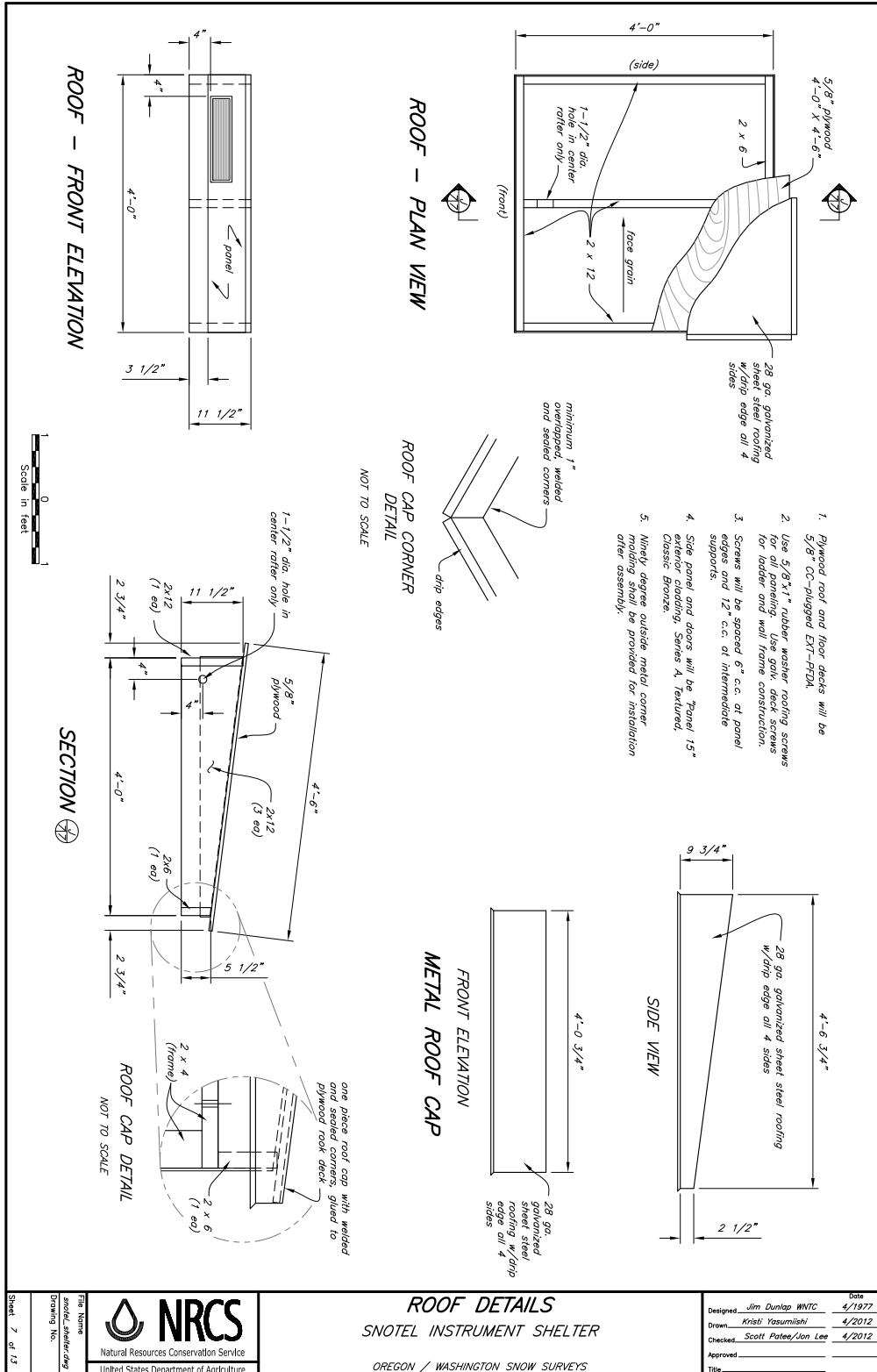
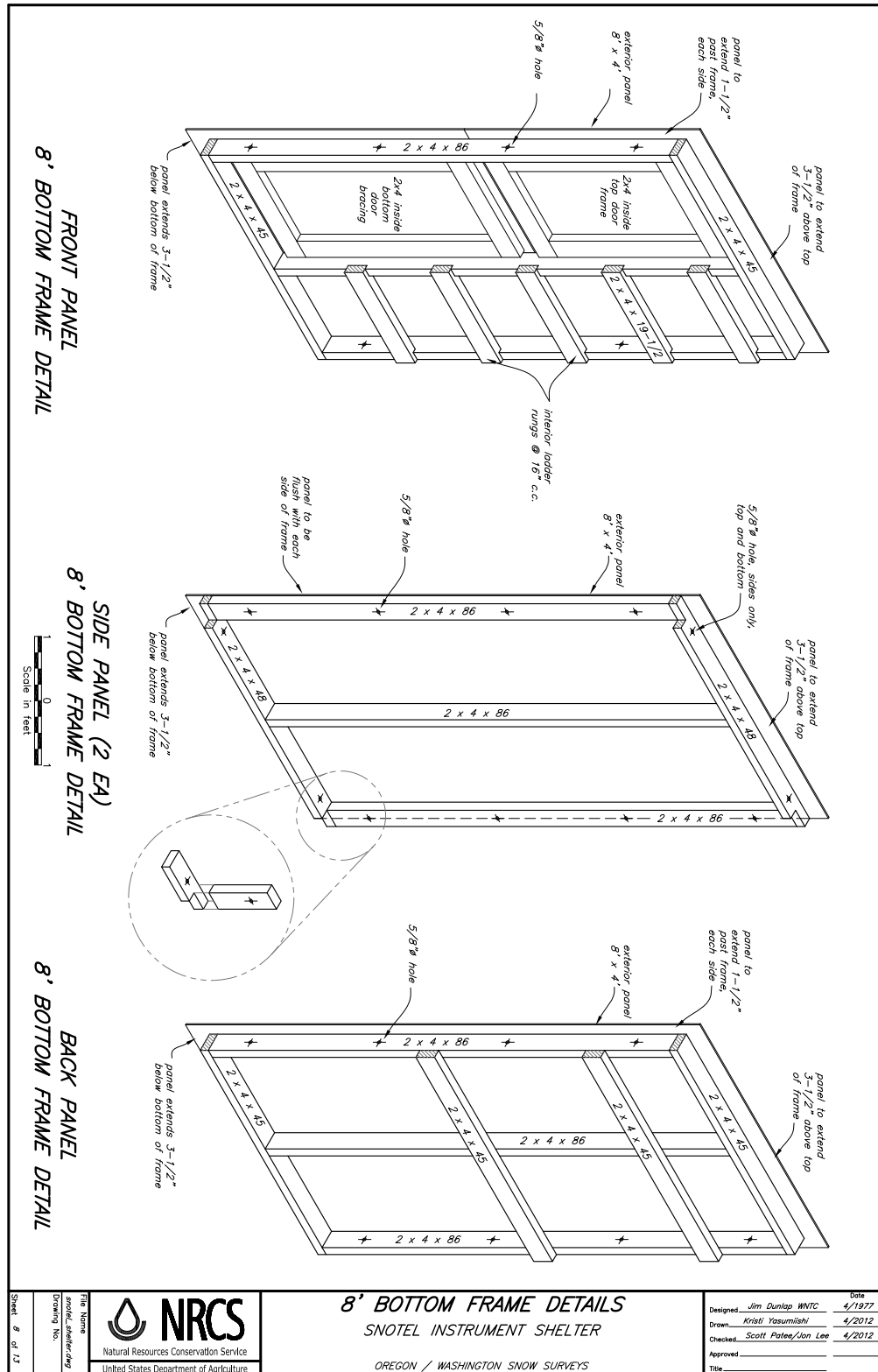

Figure 8G-4 SNOTEL shelter, 8 of 13—continued



<p>NRCS Natural Resources Conservation Service United States Department of Agriculture</p>	File Name SNOTEL shelter.dwg
	Drawing No. 8 of 13

8' BOTTOM FRAME DETAILS
SNOTEL INSTRUMENT SHELTER

OREGON / WASHINGTON SNOW SURVEYS

Designed: Jim Dunlap WNTC Drawn: Kristi Yasumishi Checked: Scott Patee/Jon Lee Approved: _____ Title: _____	Date 4/1977 4/2012 4/2012
---	------------------------------------

Figure 8G-4 SNOTEL shelter, 9 of 13—continued

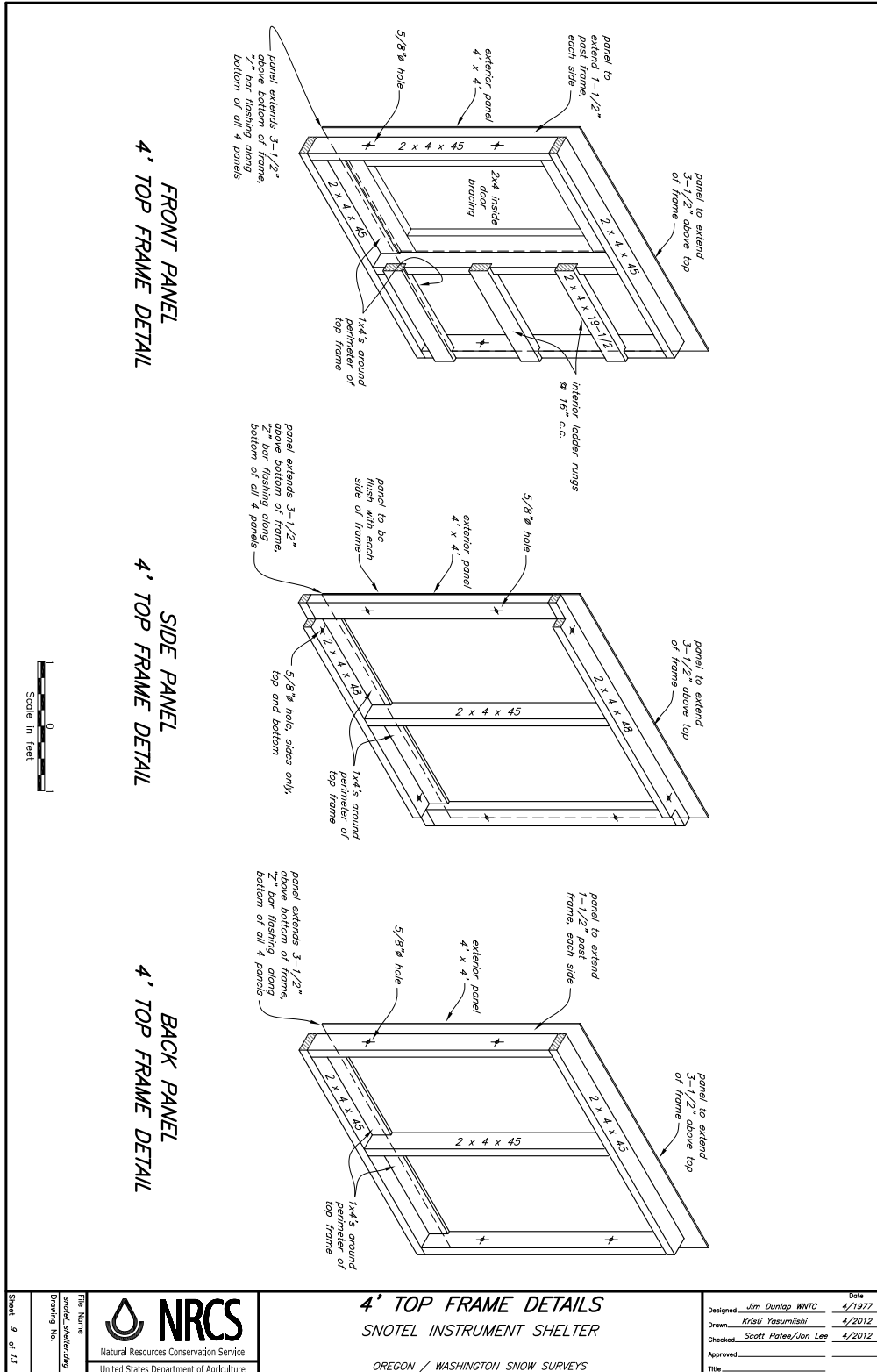

Figure 8G-4 SNOTEL shelter, 10 of 13—continued

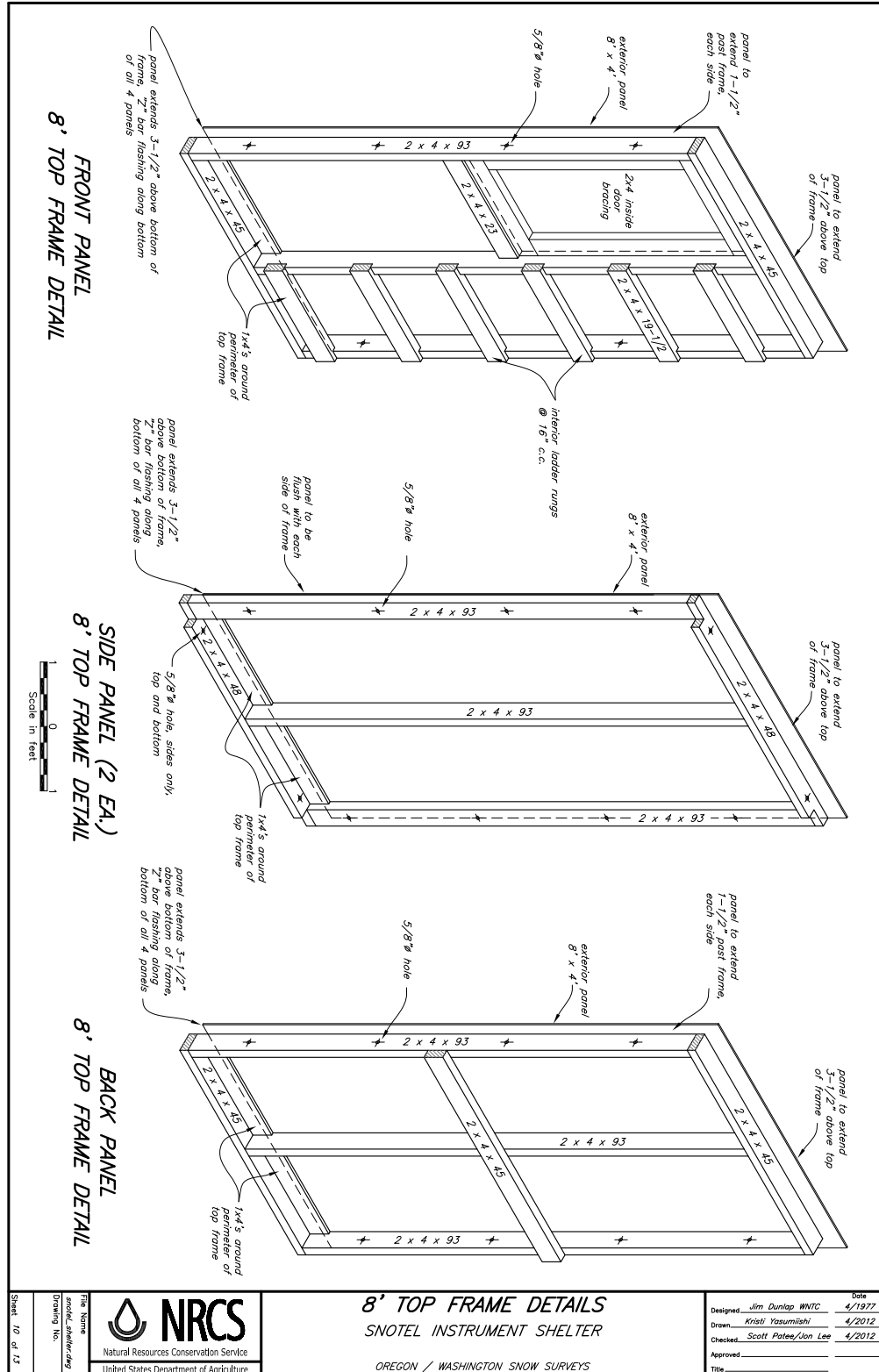

Figure 8G-4 SNOTEL shelter, 11 of 13—continued

STANDARD BASE		
QUANTITY	SIZE	SPECIFICS
4	2x4x8	pressure treated
2	4x4x8	pressure treated
1	48x48x5/8	cdx plywood
1	48x48x1/4	galv. wire mesh
4	12x1/2	galv. f-bolts
		coated exterior screws

8' FRONT PANEL FRAMING (BOTTOM UNIT)		
QUANTITY	SIZE	SPECIFICS
2	2x4x8	pressure treated
3	2x4x6	pressure treated
1	48x96	sheet siding
2	2x6	metal corners
3		coated exterior screws
		roofing screws

8' SIDE PANELS (2) FRAMING (TOP & BOTTOM UNITS)		
QUANTITY	SIZE	SPECIFICS
4	2x4x8	pressure treated
6	2x4x6	pressure treated
2	48x96	sheet siding
2	48x3/4	"2" bar flashing (top unit only)
16	4-1/2x1/2	carriage bolts w/nuts & washers
3		coated exterior screws
		roofing screws
2	1x4x8	support (top unit only)
		siliconized caulk

8' BOTTOM UNIT LOWER DOOR		
QUANTITY	SIZE	SPECIFICS
2	2x4x4	pressure treated
2	2x4x8	pressure treated
2	2x4x8	sheet siding
1	6	heavy duty chain bolt
2	4-1/4x6	heavy duty hinge
2	2-1/2x1/4	carriage bolt w/nuts & washers
10		coated exterior screws
		roofing screws

8' BACK PANEL FRAMING (TOP & BOTTOM UNITS)		
QUANTITY	SIZE	SPECIFICS
4 (3 top)	2x4x8	pressure treated
3	2x4x6	pressure treated
1	48x96	sheet siding
2	2x6	metal corners
1	48x3/4	"2" bar flashing (top unit only)
1 (bottom)	4x10	galv. lower /screen & damper
3		coated exterior screws
		roofing screws
1	1x4x8	support (top unit only)

8' BOTTOM UNIT UPPER DOOR		
QUANTITY	SIZE	SPECIFICS
2	2x4x4	pressure treated
2	2x4x8-1/2	pressure treated
2	2x4x8-1/2	sheet siding
1	5	extra heavy duty barrel bolt
2	4-1/4x6	heavy duty hinge
10	2-1/2x1/4	galv. carriage bolt w/nuts & washers
3		coated exterior screws
		roofing screws

8' INTERIOR LADDER RUNGS (BOTTOM UNIT)		
QUANTITY	SIZE	SPECIFICS
4	2x4x19-1/2	pressure treated
3		coated exterior screws

8' UNIT EXTERNAL LADDER (BOTTOM UNIT)		
QUANTITY	SIZE	SPECIFICS
2	2x4x7	pressure treated
4	2x4x17-7/8	pressure treated
4		coated exterior screws
8	1-1/2x3/8	galv. ladder supports
8	2x3/8	galv. log bolts
		galv. machine bolts w/washers

STANDARD ROOF CAP		
QUANTITY	SIZE	SPECIFICS
4	2x4x8	pressure treated
3	2x12x8	pressure treated
1	2x6x8	pressure treated
1	48x48x5/8	cdx plywood
1	28 gage	galv. roof cap
1	4x10	galv. lower /screen & damper
3		coated exterior screws
		roofing screws

Bill of Material quantities and specifics are approximate. Refer to drawings for detailed information.

UNITS ARE IN INCHES UNLESS OTHERWISE NOTED.

<p>File Name Snotel_Shelter.dwg Drawing No. Sheet 11 of 13</p>	<p>BILL OF MATERIALS SNOTEL INSTRUMENT SHELTER</p> <p>OREGON / WASHINGTON SNOW SURVEYS</p>	<p>Date 4/1977 Designed <u>Jim Dunlap WNTC</u> 4/2012 Drawn <u>Kristi Yasumishi</u> 4/2012 Checked <u>Scott Patee/Ion Lee</u> 4/2012 Approved _____ Title _____</p>
--	---	---

Figure 8G-4 SNOTEL shelter, 12 of 13—continued

8' FRONT PANEL FRAMING (TOP UNIT)		4' TOP UNIT SIDE PANEL (2)		4' TOP UNIT INTERIOR LADDER	
QUANTITY	SIZE	SPECIFICS	QUANTITY	SIZE	SPECIFICS
2	2x4x48	pressure treated	10	2x4x48	pressure treated
3	2x4x96	pressure treated	2	48x48	sheet siding
1	48x96	sheet siding	2	48x3/4	Z-bar (top unit only)
2	2x96	metal corners	8	4-1/2x1/2	carriage bolts w/nuts & washers
1	48x3/4	Z-bar flashing	3		coated exterior screws
3		coated exterior screws	2	1x4x48	support
		roofing screws			siliconized caulk
		support (top unit only)			
		siliconized caulk			

8' UNIT TOP DOOR		4' TOP UNIT SIDE PANEL (2)		4' TOP UNIT EXTERNAL LADDER	
QUANTITY	SIZE	SPECIFICS	QUANTITY	SIZE	SPECIFICS
2	2x4x24	pressure treated	10	2x4x48	pressure treated
2	2x4x40	pressure treated	2	48x48	sheet siding
2	23-3/4x40	sheet siding	2	48x3/4	Z-bar (top unit only)
1	5	extra heavy duty barrel bolt	8	4-1/2x1/2	carriage bolts w/nuts & washers
2	4-1/4x6	heavy duty hinge	3		coated exterior screws
10	2-1/2x1/4	golk, carriage bolt w/nuts & washers	2	1x4x48	support
		coated exterior screws			siliconized caulk
		roofing screws			

8' INTERIOR LADDER (TOP UNIT)		4' TOP UNIT INTERIOR LADDER			
QUANTITY	SIZE	SPECIFICS	QUANTITY	SIZE	SPECIFICS
5	2x4x19-1/2	pressure treated	2	2x4x44-1/2	pressure treated
20	3	coated exterior screws	3	2x4x17-7/8	pressure treated
			4	3	coated exterior screws
			8	1-1/2x3/8	golk, lag bolts
				2 x 3/8	golk, machine bolts w/nuts & washers

8' EXTERNAL LADDER (TOP UNIT)		
QUANTITY	SIZE	SPECIFICS
2	2x4x92-1/2	pressure treated
6	2x4x17-7/8	pressure treated
24	3	coated exterior screws
4		golk, ladder supports
8	1-1/2x3/8	golk, lag bolts
8	2 x 3/8	golk, machine bolts w/nuts & washers

4' TOP UNIT SIDE PANEL (2)		
QUANTITY	SIZE	SPECIFICS
5	2x4x48	pressure treated
1	48x48	sheet siding
1	2x96	metal corners
1	48x3/4	Z-bar flashing (top unit only)
1	4-1/2x1/2	carriage bolts w/nuts & washers
1	1x4x48	support
1		siliconized caulk

Bill of Material quantities and specifics are approximate. Refer to drawings for detailed information.

UNITS ARE IN INCHES UNLESS OTHERWISE NOTED.



BILL OF MATERIALS
SNOTEL INSTRUMENT SHELTER

OREGON / WASHINGTON SNOW SURVEYS

Designed	Jim Dunlap WNTC	Date	4/1977
Drawn	Kristi Yasumishi		4/2012
Checked	Scott Patey/Ion Leo		4/2012
Approved			
Title			

Figure 8G-4 SNOTEL shelter, 13 of 13—continued

8 FT SHELTER			12 FT SHELTER			16 FT SHELTER		
QUANTITY	SIZE (in)	SPECIFICS	QUANTITY	SIZE (in)	SPECIFICS	QUANTITY	SIZE (in)	SPECIFICS
54'	2x4	7-8' pressure treated	78'	2x4	10-8' pressure treated	91'	2x4	12-8' pressure treated
8'	4x4	pressure treated	8'	4x4	pressure treated	8'	4x4	pressure treated
127'	2x4	16-8' boards	207'	2x4	26-8' boards	268'	2x4	34-8' boards
4'	2x6	pressure treated	4'	2x6	pressure treated	4'	2x6	pressure treated
12'	2x12	pressure treated	12'	2x12	pressure treated	12'	2x12	pressure treated
4	48x96	sheet siding	6	48x96	sheet siding	8	48x96	sheet siding
4	2x96	metal corners	6	2x96	metal corners	8	2x96	metal corners
1	48x96x5/8	cdx plywood	1	48x96x5/8	cdx plywood	1	48x96x5/8	cdx plywood
1	48x48x1/4	galv. wire mesh	1	48x48x1/4	galv. wire mesh	1	48x48x1/4	galv. wire mesh
1	28 gage	galv. roof cap	1	28 gage	galv. roof cap	1	28 gage	galv. roof cap
2	4x10	galv. louver/screen & damper	2	4x10	galv. louver/screen & damper	2	4x10	galv. louver/screen & damper
4	4-1/4x6	heavy duty hinge	2	6x3/4	2" bar flashing	2	6x3/4	2" bar flashing
1	6	heavy duty chain bolt	6	4-1/4x6	heavy duty hinge	3	4-1/4x6	heavy duty hinge
1	5	extra heavy duty barrel bolt	1	6	heavy duty chain bolt	1	6	heavy duty chain bolt
5 lbs.	3	coated exterior screws	2	5	extra heavy duty barrel bolt	2	5	extra heavy duty barrel bolt
4		galv. ladder supports	8 lbs.	3	coated exterior screws	10 lbs.	3	coated exterior screws
8	1-1/2x3/8	galv. lag bolts	8		galv. ladder supports	8		galv. ladder supports
8	2x3/8	galv. machine bolts w/nuts & washers	16	1-1/2x3/8	galv. lag bolts	16	1-1/2x3/8	galv. lag bolts
5 lbs.	1x5/8	roofing screws	16	2x3/8	galv. machine bolts w/nuts & washers	16	2x3/8	galv. machine bolts w/nuts & washers
14	2-1/2x1/4	galv. carriage bolts w/nuts & washers	8 lbs.	1x5/8	roofing screws	10 lbs.	1x5/8	roofing screws
16	4-1/2x1/2	carriage bolts w/nuts & washers	24	2-1/2x1/4	galv. carriage bolts w/nuts & washers	24	2-1/2x1/4	galv. carriage bolts w/nuts & washers
12	12x1/2	galv. j-bolts	24	4-1/2x1/2	galv. carriage bolts w/nuts & washers	32	4-1/2x1/2	galv. carriage bolts w/nuts & washers
			4	12x1/2	galv. j-bolts	4	12x1/2	galv. j-bolts
			16'	1x4x8	support	20'	1x4x8	support

Bill of Material quantities and specifics are approximate. Refer to drawings for detailed information.

UNITS ARE IN INCHES UNLESS OTHERWISE NOTED.



BILL OF MATERIALS
SNOTEL INSTRUMENT SHELTER
OREGON / WASHINGTON SNOW SURVEYS

Designed	Jim Dunlap WNTC	Date	4/1977
Drawn	Kristi Yasumishi		4/2012
Checked	Scott Patee/Ion Lee		4/2012
Approved			
Title			

Figure 8G-5 Snow course marker



Figure 8G-6 Storage precipitation gage, 1 of 5

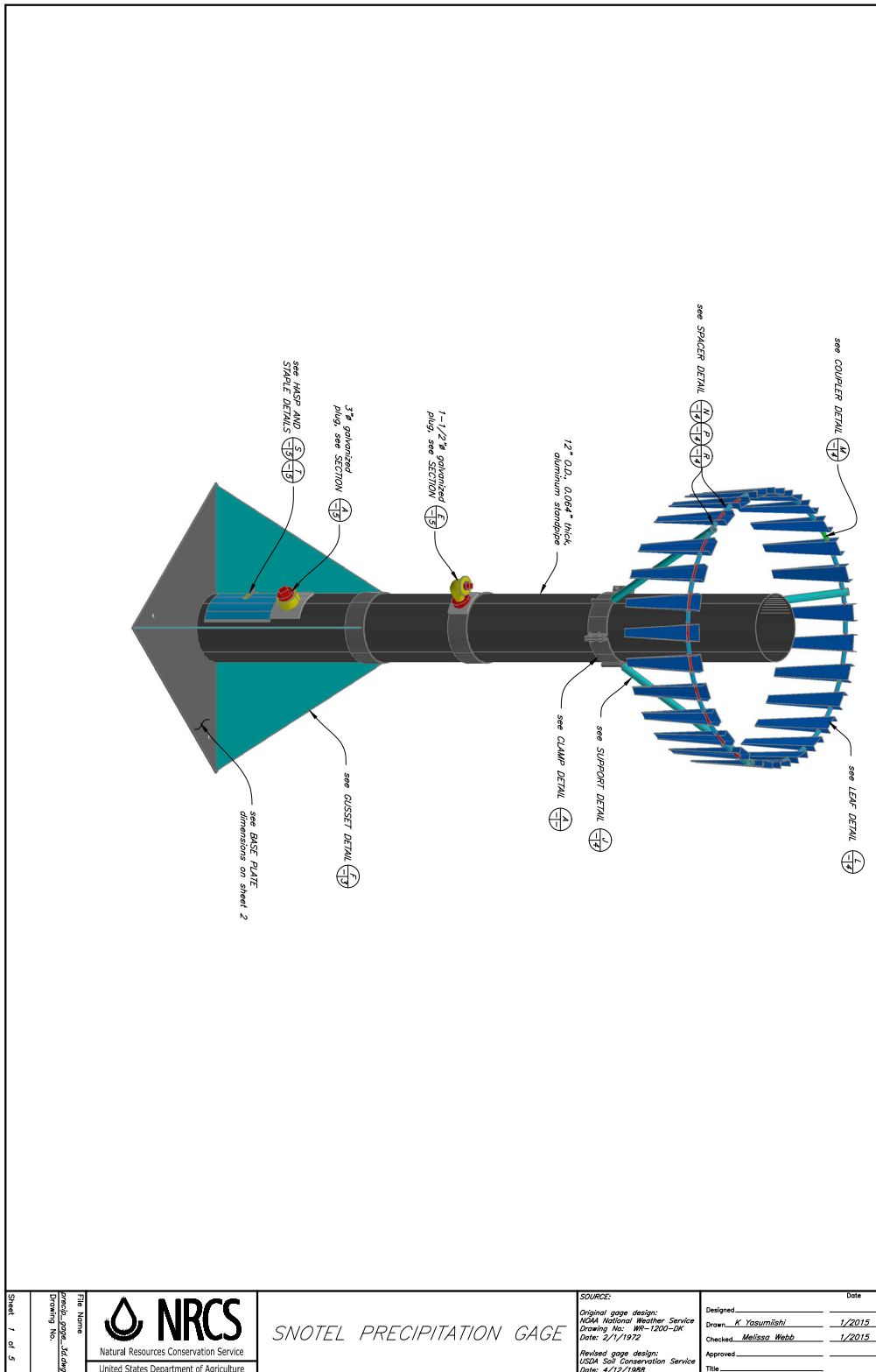

Figure 8G-6 Storage precipitation gage, 2 of 5—continued

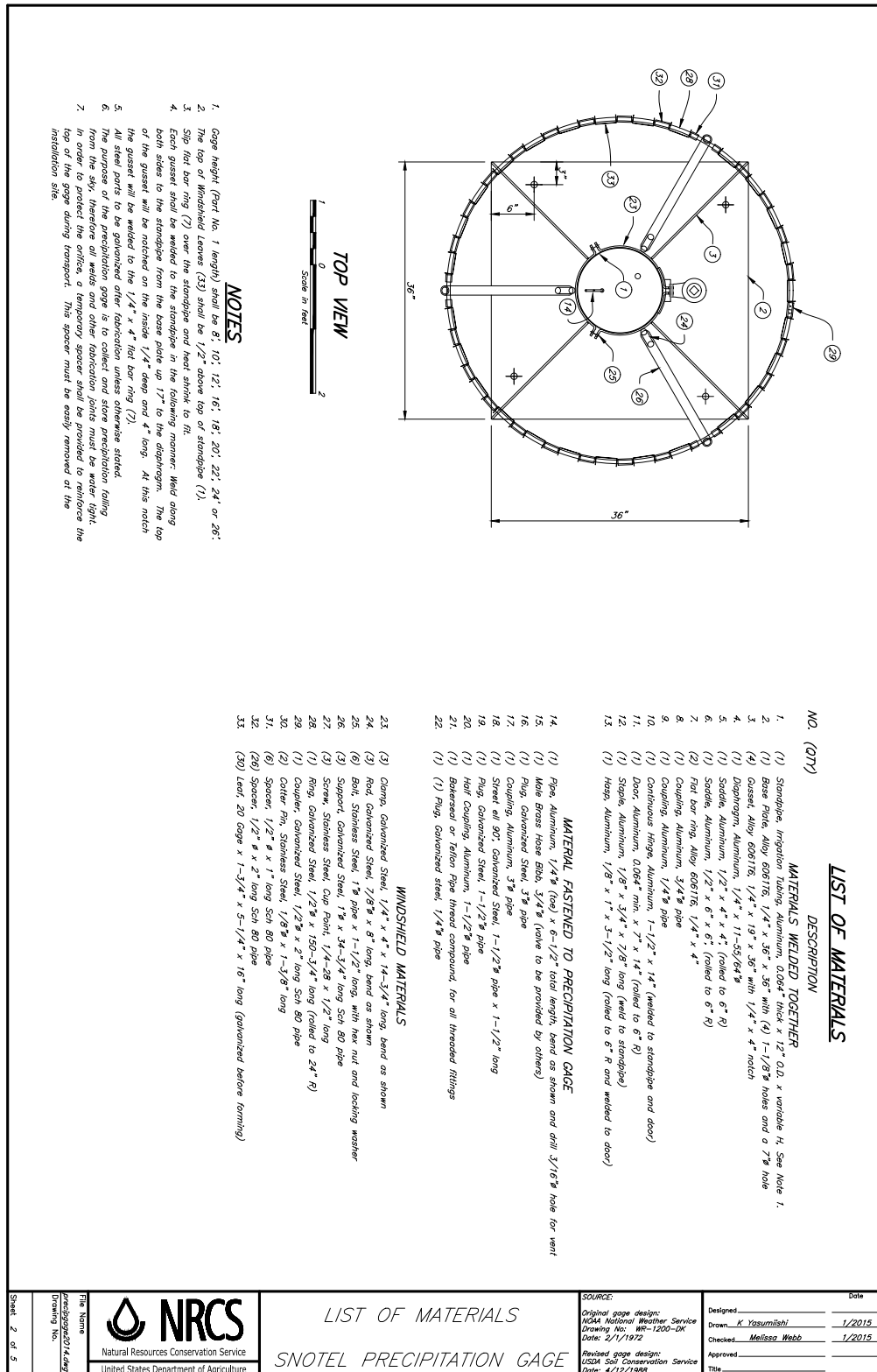

Figure 8G-6 Storage precipitation gage, 3 of 5—continued

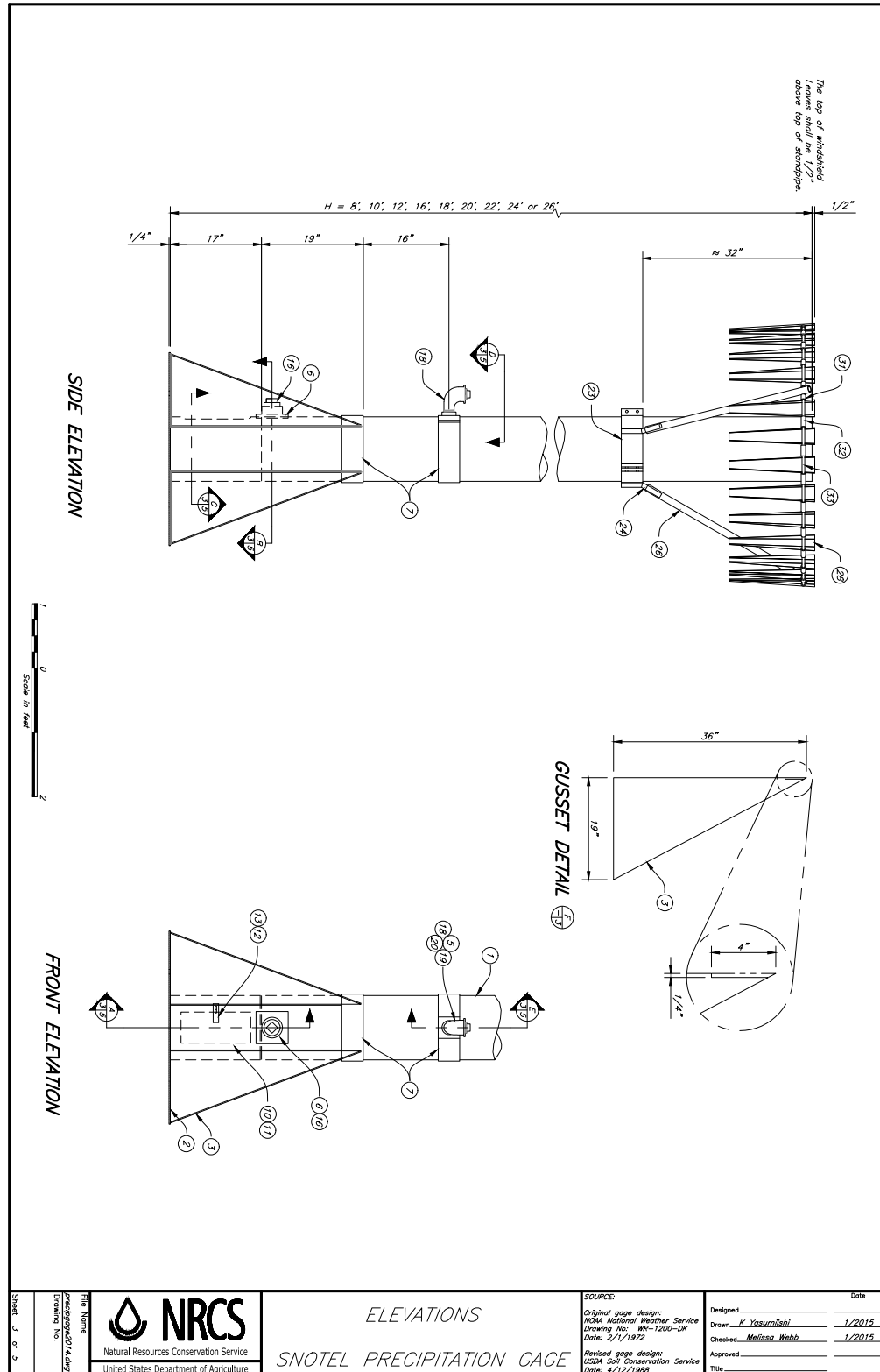
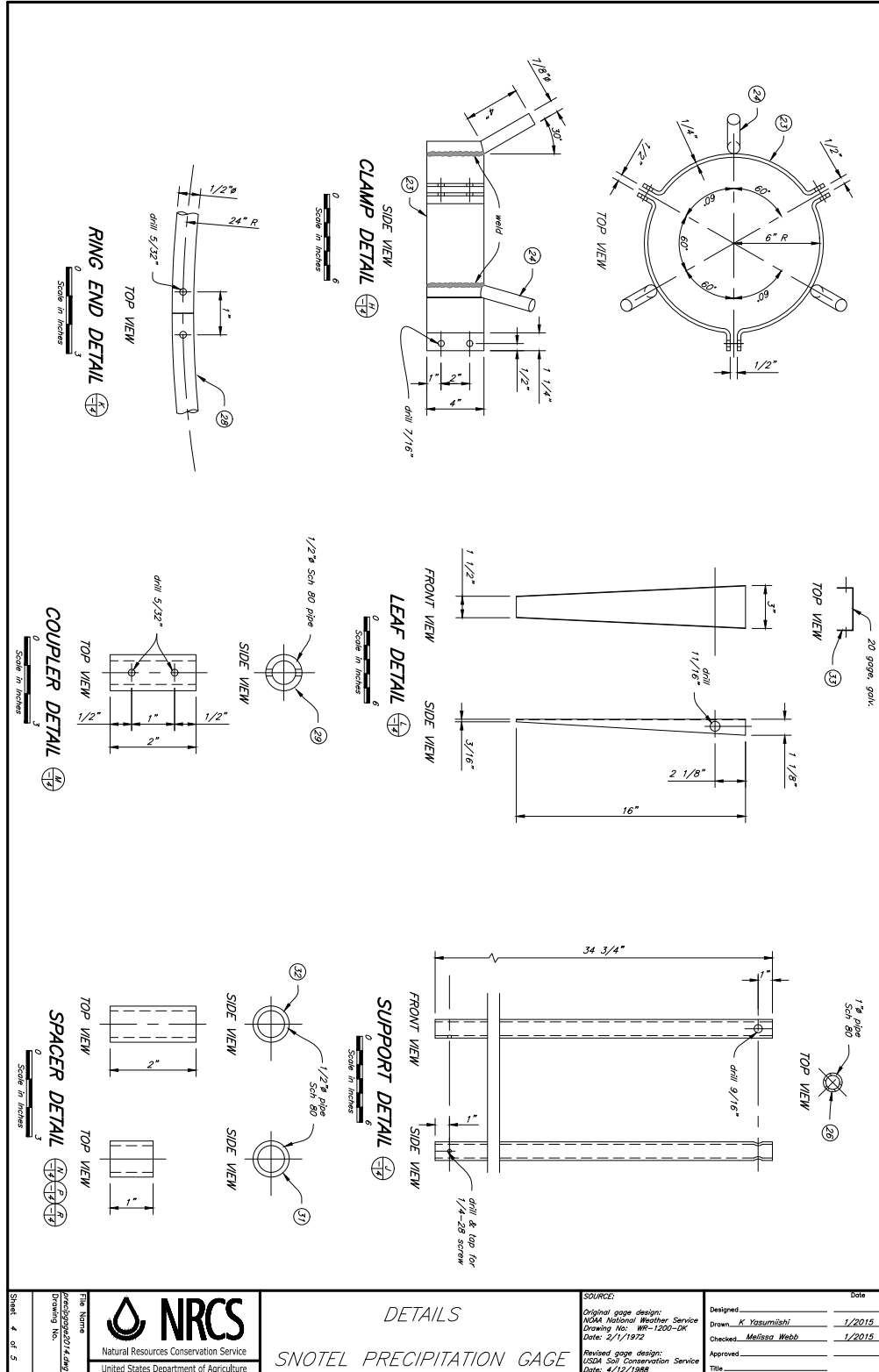
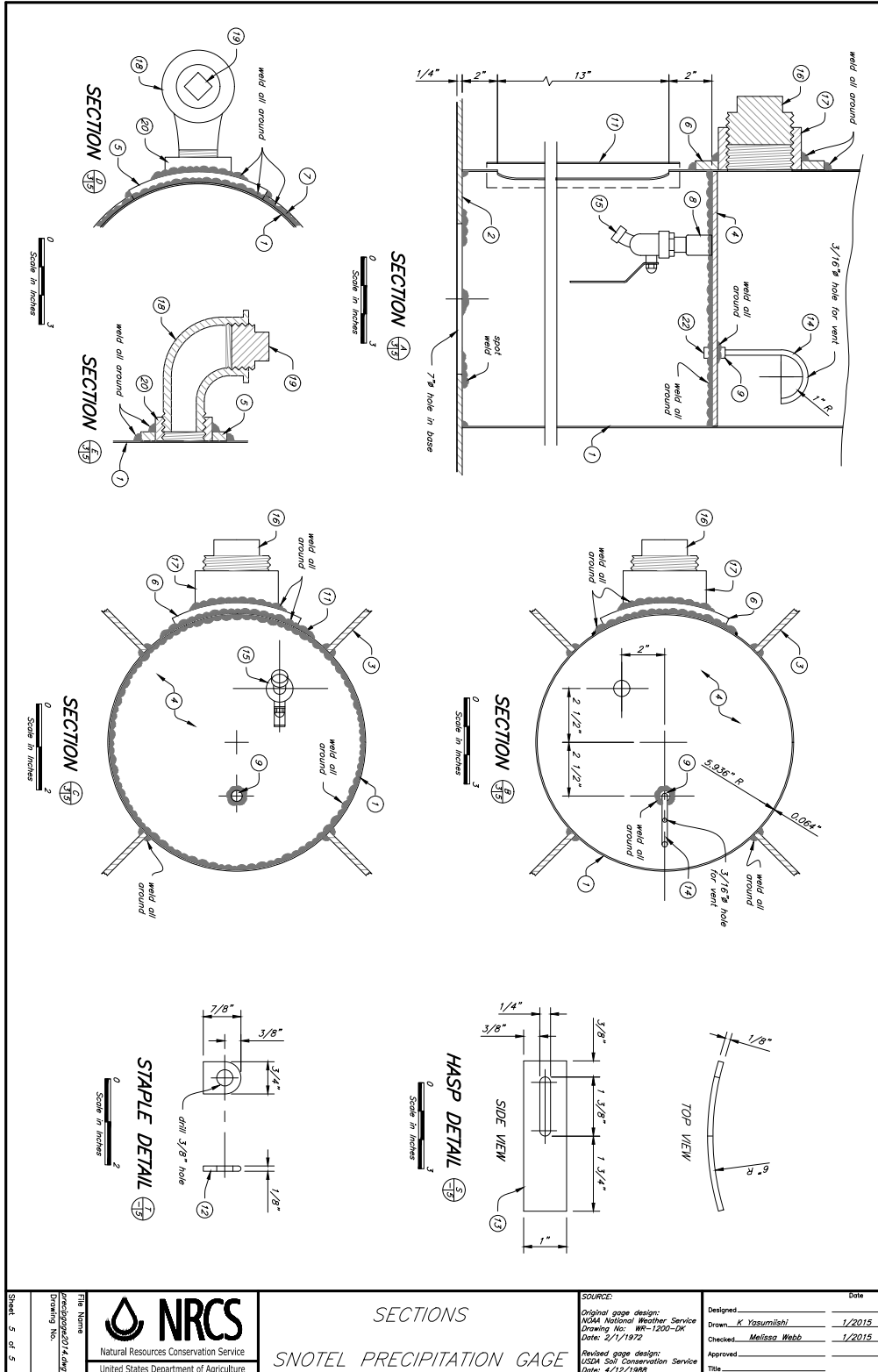

Figure 8G-6 Storage precipitation gage, 4 of 5—continued



<p>Sheet 4 of 5</p>	<p>Project: 090902014-KAW Drawing No.</p>	<p>The NRCS Natural Resources Conservation Service United States Department of Agriculture</p>	<p>DETAILS SNOTEL PRECIPITATION GAGE</p>	<p>SOURCE: Original gage design: NRCS National Weather Service Drawing No. WR-1200-DK Date: 2/1/1972</p>	<p>Date</p>
				<p>Revised gage design: USDA Soil Conservation Service Date: 4/12/1988</p>	<p>Designed: _____ Drawn: K. Yasumishi 1/2015 Checked: Melissa Webb 1/2015 Approved: _____ Title: _____</p>

Figure 8G-6 Storage precipitation gage, 5 of 5—continued



 Natural Resources Conservation Service
 United States Department of Agriculture

SECTIONS
 SNOTEL PRECIPITATION GAGE

SOURCE:
 Original gage design:
 NOAA National Weather Service
 Drawing No: WR-1200-DK
 Date: 2/1/1972
 Revised gage design:
 USCS Soil Conservation Service
 Date: 4/12/1988

Date _____
 Designed: _____
 Drawn: K. Yasumishi 1/2015
 Checked: Melissa Webb 1/2015
 Approved: _____
 Title: _____

File Name: precipgag2014.dwg
 Drawing No. _____
 Sheet: 5 of 5