



Issued August 2007

Cover photo: Pile foundations may be needed where the bearing strength of the earth materials is low.

Advisory Note

Techniques and approaches contained in this handbook are not all-inclusive, nor universally applicable. Designing stream restorations requires appropriate training and experience, especially to identify conditions where various approaches, tools, and techniques are most applicable, as well as their limitations for design. Note also that product names are included only to show type and availability and do not constitute endorsement for their specific use.

Contents

Purpose	TS14F-1
Introduction	TS14F-1
Bearing capacity	TS14F-1
Lateral load capacity	TS14F-4

Tables

Table TS14F-1	Prescriptive values for cohesionless soils	TS14F-2
Table TS14F-2	Prescriptive values for cohesive soils	TS14F-3

Figures

Figure TS14F-1	Schematic showing applied lateral force and assumed soil reactions for single rigid pile driven into a cohesive soil. Concentrated load applied at top of pile	TS14F-5
Figure TS14F-2	Schematic showing applied lateral force and assumed soil reactions for a single rigid pile driven into a cohesive soil. Uniformly decreasing load applied	TS14F-5
Figure TS14F-3	Schematic showing applied lateral force and assumed soil reactions for single rigid pile driven into a cohesive soil. Concentrated load applied at top of pile	TS14F-6
Figure TS14F-4	Schematic showing applied lateral force and assumed soil reactions for single rigid pile driven into a cohesive soil. Uniformly decreasing load applied as shown	TS14F-6

Purpose

Piles are used to transfer foundation forces through relatively weak soil to stronger strata to minimize settlement. The most likely applications for pile foundations in stream restoration and stabilization projects are as support for bank stabilization structures (retaining wall) and anchors for large woody material (LWM). Piles may be used to support ancillary structures such as culverts, structural channels, bridges, and pumping stations. This technical supplement addresses the analyses required to design pile foundations.

Introduction

Foundation structures may be classified into two categories: shallow and deep. There is no specific rule that defines when a particular structure is considered to be shallow or deep. In general, shallow structures are constructed fairly close to ground surface and are usually constructed upwards from the bottom surface of an excavation.

Traditionally, deep foundations refer to piles that are driven into the ground. However, piles are sometimes set into holes that are prebored or drilled into the ground. A hole bored into the ground and filled with concrete is called a drilled shaft. Usually, reinforcing steel is placed into the drilled hole just prior to placement of the concrete. Other terms for drilled shafts are: drilled piers, drilled caissons, cast-in-place piles, cast-in-drilled-hole piles, and augered piles. Another type of drilled shaft foundation is an auger-cast pile.

Piles are normally used to provide foundation capacity to support a structure when the bearing capacity of the soil is insufficient to do so. If a soil's bearing capacity is less than that needed to support a structure, a shallow foundation may become impractical or expensive. By driving piles into the ground, the pile structure can take advantage of the soil's shear strength, as well as its compressive (or bearing) strength. Piles are also used to transfer foundation forces through relatively weak soil strata to stronger strata to minimize settlement.

Piles may be steel H-sections; steel pipe; precast, prestressed concrete; concrete-filled steel shells; or

timber. Piles with solid cross sections, or hollow piles with closed ends, typically displace the soil as they are driven and are termed *displacement* piles. Piles with open cross sections, such as H-sections, or pipe piles without closed ends, typically cut through the soil, rather than displacing it as they are driven, so they are termed *nondisplacement* piles. Whether a pile behaves in a displacing or nondisplacing manner depends heavily on the soil properties. Pile driving may cause cohesive soils to remold and cause density changes in cohesionless soils. These changes may result in ground surface elevation changes (heaving or settling) in the general area of the driving operation. Proper pile driving equipment selection and operation can greatly minimize the possible adverse effects of pile installation.

Pile foundations are used in stream restoration and stabilization projects as support for bank stabilization (retaining wall) structures and anchors for LWM. Piles may be used to support ancillary structures such as culverts, structural channels, bridges, and pumping stations.

Piles are typically installed using specialized pile driving equipment. The motive force that drives the pile into the ground is applied by a pile driving hammer, which is attached to the top of a pile. A crane is used to support the pile driving equipment and handle the individual piles.

Bearing capacity

The allowable bearing or axial capacity of a driven pile may be determined from the following equation:

$$Q_{\text{Allowable}} = \frac{Q_{\text{total}}}{\text{factor of safety}} \quad (\text{eq. TS14F-1})$$

$$Q_{\text{total}} = Q_{\text{point}} + Q_{\text{friction}} - W_{\text{t}_{\text{pile}}} \quad (\text{eq. TS14F-2})$$

where:

Q_{total} = ultimate capacity of pile
 Q_{point} = end-bearing capacity of pile
 Q_{friction} = capacity due to friction along length of pile

$W_{\text{t}_{\text{pile}}}$ = weight of pile

factor of safety = 3.0

For a cohesionless soil, the following formulas may be used to determine values (table TS14F-1) for the components of the bearing capacity equation:

$$Q_{\text{point}} = \gamma' DN'_q A_{\text{point}} \quad (\text{eq. TS14F-3})$$

where:

γ' = effective unit weight of soil

D = embedded depth of pile

A_{point} = area of pile tip

$$N'_q = e^{\pi \tan \phi'} \tan^2 \left(45^\circ + \frac{\phi'}{2} \right) \quad (\text{eq. TS14F-3a})$$

where:

$$\phi' = \tan^{-1} (0.67 \tan \phi)$$

ϕ = angle of internal friction of soil

$$Q_{\text{friction}} = \tau'_{\text{average}} \sum_o K_{\text{shape}} D \quad (\text{eq. TS14F-4})$$

where:

$$\tau'_{\text{average}} = \gamma' z K_o \tan \phi' \quad (\text{eq. TS14F-4a})$$

where:

γ' = effective unit weight of soil

z = depth (along pile) at point of analysis

K = ratio of lateral to vertical soil stress on pile

K_o = 0.7 for piles loaded in compression

K_o = 0.5 for piles loaded in tension

ϕ'_o = $\tan^{-1}(0.67 \tan \phi)$

ϕ = soil angle of internal friction

Σ_o = perimeter of pile

K_{shape} = pile shape factor

K_{shape} = 1.000 for round perimeter

K_{shape} = 0.785 for square perimeter

I-beam piles are considered to have a square perimeter with side lengths equivalent to their respective depth and width dimensions.

= 0.95 for octagon perimeter

= 0.84 for hexagon perimeter

= 0.60 for triangular perimeter

D = depth of pile

Table TS14F-1 Prescriptive values for cohesionless soils

Soil type	Angle of internal friction (°)	Angle of friction between soil and pile (°)	Bearing capacity coefficient N_q	Maximum allowable capacity, Q	
				Friction (tons/ft ²)	Bearing (tons/ft ²)
Clean sand	35	30	11	1.00	100
Silty sand	30	25	7	0.85	50
Sandy silt	25	20	5	0.70	30
Silt	20	15	4	0.50	20

For a cohesive soil, the following formulas may be used to determine values (table TS14F-2) for the components of the bearing capacity equation cited above.

$$Q_{\text{point}} = A_{\text{point}} (7.4c + \gamma' D) \quad (\text{eq. TS14F-5})$$

where:

A_{point} = area of pile tip

c = shear strength of cohesive soil at pile tip depth

γ' = effective unit weight of soil

D = depth of pile

$$Q_{\text{friction}} = c'_{\text{average}} \sum_o K_{\text{shape}} D \quad (\text{eq. TS14F-6})$$

where:

c'_{average} = average effective shear stress of soil, along with a given length, or segment of the pile

\sum_o = perimeter of pile

K_{shape} = pile shape factor

K_{shape} = 1.000 for round perimeter

= 0.785 for square perimeter

I-beam piles are considered to have a square perimeter with side lengths equivalent to their respective depth and width dimensions.

= 0.95 for octagon perimeter

= 0.84 for hexagon perimeter

= 0.60 for triangular perimeter

D = depth of pile or length of pile segment

Table TS14F-2 Prescriptive values for cohesive soils

Clay	Shear strength
Normally consolidated	$c_z = 0.5\gamma'z(1 - K_o)$
Underconsolidated	$c_z = 0.125\gamma'z(1 - K_o)$
Overconsolidated by erosion	$c_z = 600 \text{ lb/ft}^2 + 0.5\gamma'z(1 - K_o)$
Overconsolidated by desiccation	$c_z = 2,000 \text{ lb/ft}^2$ for $z = 0 \text{ ft to } 20 \text{ ft}$
	$c_z = 1,200 \text{ lb/ft}^2$ for $z = 20 \text{ ft to } 60 \text{ ft}$
	$c_z = 3,000 \text{ lb/ft}^2$ for $z = 60 \text{ ft to } 160 \text{ ft}$
	For highly fissured clays, use the following:
	$c' = 0$
	$\phi' = 5^\circ \text{ to } 10^\circ$ and
	$\tau'_{\text{average}} = \gamma'z K_o \tan \phi'$

Notes:

For piles loaded in axial compression, $K_o = 0.7$

For piles loaded in axial tension, $K_o = 0.5$

Effective shear strength, $c' = 0.67c$

Z = depth along pile from ground surface (ft) $Z = 0$ at ground surface

Lateral load capacity

An approximate lateral capacity of a short, rigid pile driven into a cohesive soil can be determined from the following equation (figs. TS14F-1 and TS14F-2):

$$P_{\text{Allowable}} = \frac{P_{\text{Ultimate}}}{\text{factor of safety}} \quad (\text{eq. TS14F-7})$$

where:

$P_{\text{Allowable}}$ = allowable lateral load applied to exposed portion of pile
factor of safety = 3

$$P_{\text{Ultimate}} = \sigma B \left[\left(\sqrt{4 \left(\frac{D}{2} + H \right)^2 + D^2} \right) - 2 \left(\frac{D}{2} + H \right) \right] \quad (\text{eq. TS14F-8})$$

where:

σ = allowable soil stress, $\sigma = 9c$
 B = width or diameter of pile
 D = depth of pile embedment
 H = height of pile (above ground) to centroid of applied load

If a design load is known, the required depth of embedment may be determined from the following equation:

$$D = \frac{P_{\text{Ultimate}}}{\sigma B} + \sqrt{2 \left(\frac{P_{\text{Ultimate}}}{\sigma B} \right)^2 + \frac{4HP_{\text{Ultimate}}}{\sigma B}} \quad (\text{eq. TS14F-9})$$

For most stream restoration and stabilization applications, a driven pile may be considered to be rigid when:

$$\frac{H}{B} \leq 12 \quad (\text{eq. TS14F-10})$$

An approximate allowable lateral load for a short, rigid pile driven into a **cohesionless** soil may be determined using the following equation (figs. TS14F-3 and TS14F-4).

$$P_{\text{Allowable}} = \frac{P_{\text{Ultimate}}}{\text{factor of safety}} \quad (\text{eq. TS14F-11})$$

where:

$P_{\text{Allowable}}$ = allowable lateral load applied to exposed portion of pile
factor of safety = 3

$$P_{\text{Ultimate}} = \frac{\gamma' B K_p D^2}{2(H+D)} \quad (\text{eq. TS14F-12})$$

where:

γ' = effective unit weight of soil
 B = width or diameter of pile
 K_p = passive pressure coefficient
$$= \tan^2 \left(45^\circ + \frac{\phi}{2} \right) \quad (\text{eq. TS14F-13})$$

 ϕ = soil angle of internal friction
 D = embedded depth of pile

If a design load is known, the required depth of embedment may be determined from the following equation.

$$D = \sqrt{\frac{2P_{\text{Ultimate}}}{\gamma' B K_p} (H+D)} \quad (\text{eq. TS14F-14})$$

This equation is solved iteratively until both values for D are equivalent.

Figure TS14F-1 Schematic showing applied lateral force and assumed soil reactions for single rigid pile driven into a cohesive soil. Concentrated load applied at top of pile

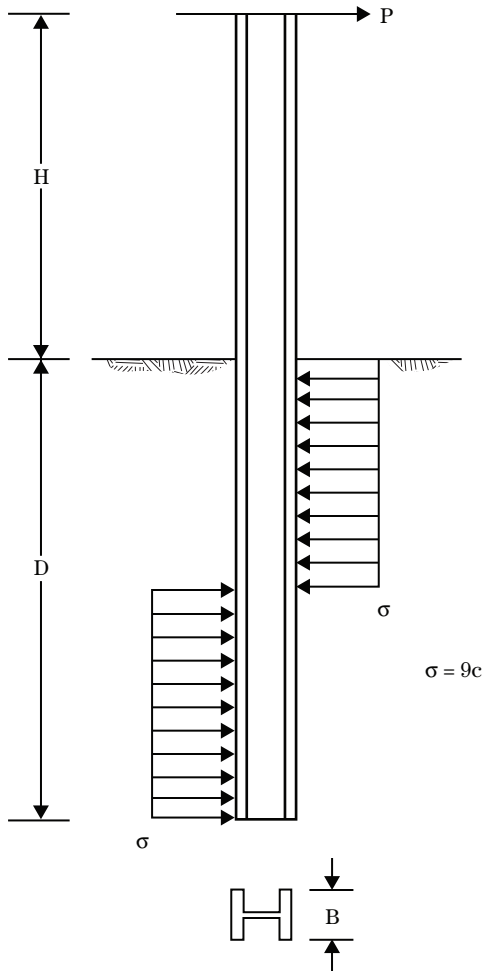

Figure TS14F-2 Schematic showing applied lateral force and assumed soil reactions for a single rigid pile driven into a cohesive soil. Uniformly decreasing load applied

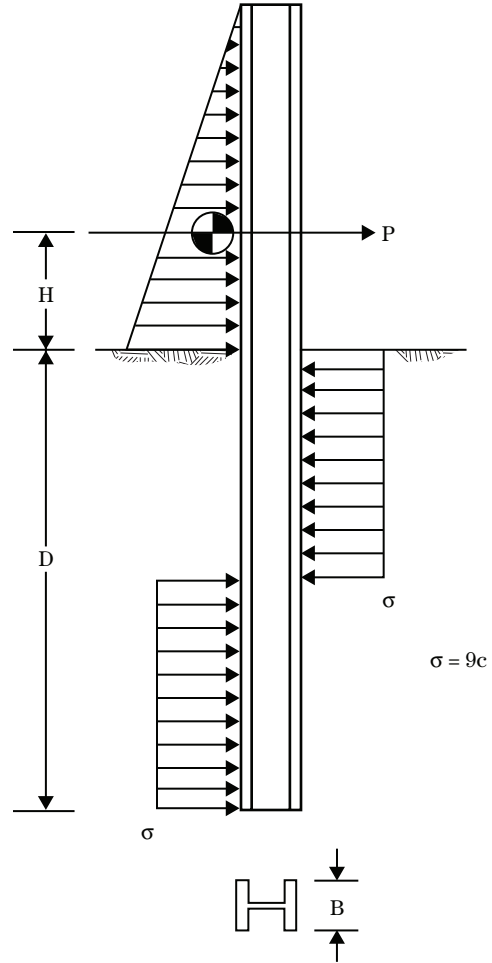

Figure TS14F-3 Schematic showing applied lateral force and assumed soil reactions for single rigid pile driven into a cohesive soil. Concentrated load applied at top of pile

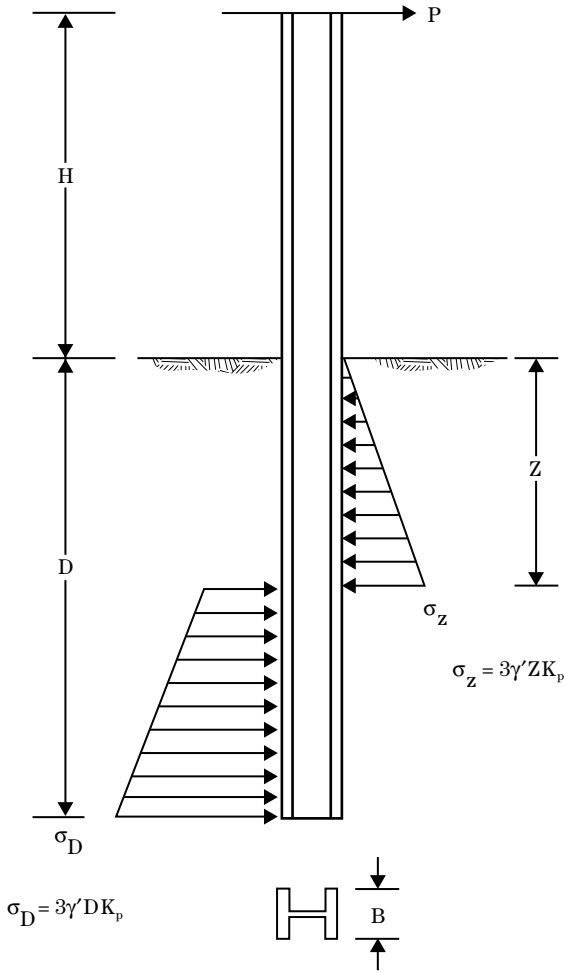

Figure TS14F-4 Schematic showing applied lateral force and assumed soil reactions for single rigid pile driven into a cohesive soil. Uniformly decreasing load applied as shown

